

# Large-Diameter Anti-Friction Slewing Rings

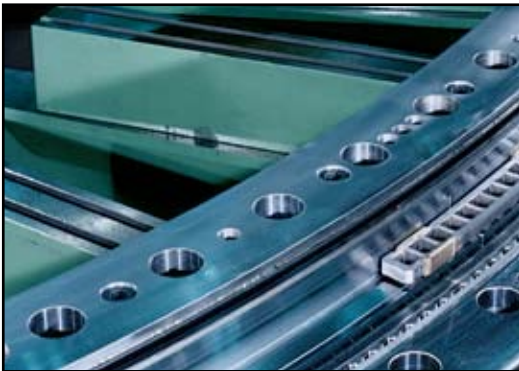

Rotek Incorporated



ThyssenKrupp

# Large-Diameter Anti-Friction Slewing Rings

## Rotek Incorporated

Rotek Incorporated  
1400 South Chillicothe Road  
Aurora, Ohio 44202-9282  
Telephone: 330/562-4000  
Toll free: 1-800-221-8043  
Fax: (Sales) 330/562-4620  
Fax: (Engineering) 330/562-2709  
[www.rottek-inc.com](http://www.rottek-inc.com)



Certificate No. 2132

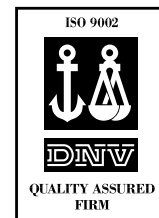

Certificate No. 2205

## Rotek: Your Best Source For Large-Diameter Slewing Rings

Rotek Incorporated offers a unique combination of experience and technology in large-diameter slewing rings. Since our founding in 1962, we've designed and manufactured thousands of large-diameter slewing rings for a wide range of applications. We pioneered big slewing ring technology for applications in power cranes and excavators, military equipment, machine tools, medical equipment, large antennas, wind turbines, and many other applications.

We've complemented our product expertise with a variety of customer-oriented business philosophies and techniques. Our Total Quality Management program and continuous improvement policy have earned certification to ISO 9001 and ISO 9002 standards.

Our integrated manufacturing capabilities – including state-of-the-art ring rolling mills, heat treating facilities, complete machining facilities, and CNC/CAD/CAM technologies - allow us to offer our customers a high-quality product with shorter lead times and reliable delivery schedules.

And, our customer services are extensive. Rotek offers experienced application engineering assistance and complete, worldwide after-the-sale services, including installation supervision, preventative maintenance programs, and in-use slewing ring analysis. Rotek also offers refurbishment and replacement programs for slewing rings which require removal from service.

This catalog will introduce you to the broad range of large-diameter slewing rings designed and manufactured by Rotek Incorporated. It will provide information that may be used to determine which Rotek slewing ring model is appropriate for your application – Please feel free to contact us for any additional information you may require, or to start the application engineering process.

Please note the following:

- Specifications and other information appearing in this catalog are subject to change without notice.
- Final selection of a slewing ring for any application must be reviewed and approved by Rotek prior to ordering.

- We suggest you read through the entire engineering data section before you begin the process of selecting a slewing ring for your specific application. Doing so will familiarize you with all of the variables that should be considered in the selection process.

☞ This symbol is used throughout the catalog to remind you to call us for technical and application assistance, current production information, and related data. Call your Rotek Sales Engineer or the Rotek Application Engineering Department at 330/562-4000 or toll-free at 800/221-8043.

- Rotek also manufactures a complete line of seamless, engineered rolled rings, in diameters from 12 inches to 240 inches; axial lengths up to 43 inches; weights up to 35,000 pounds; and in profiles from simple rectangular cross sections to complex contours. Please contact our Ring Rolling Division for more information.

<u>4</u>	<u>Overview of Rotek Incorporated</u>
<u>8</u>	<u>Product Line Summary</u>
<u>12</u>	<u>Engineering Data (with separate table of contents)</u>
<u>37</u>	<u>Design Worksheet</u>

Description, Loads and Dimensional Data for Specific Rotek Slewing Ring Series:

<u>40</u>	<u>Series 1000 Single Row Ball Slewing Rings</u>
<u>42</u>	<u>Series 2100 Single Row Ball Slewing Rings</u>
<u>49</u>	<u>Rotek Standard Pinions for Econo-Trak Slewing Rings</u>
<u>50</u>	<u>Series 3000 Single Row Ball Slewing Rings</u>
<u>58</u>	<u>Series 4000 Double Row Ball Slewing Rings</u>
<u>60</u>	<u>Series 5000 Cross Roller Slewing Rings</u>
<u>64</u>	<u>Series 6000 High Speed Ball Slewing Rings</u>
<u>66</u>	<u>Series 7100 Single Row Ball Vertical Thrust Slewing Rings</u>
<u>66</u>	<u>Series 8000 Single Row Ball Vertical Thrust Slewing Rings</u>
<u>68</u>	<u>Series 10,000 Three Row Roller Slewing Rings</u>
<u>72</u>	<u>Series 15,000 Wire Race™ Slewing Rings</u>
<u>76</u>	<u>Precision Slewing Rings</u>

## Overview: Leaders in the Design and Manufacture of Large-Diameter Slewing Rings



Since its founding in 1962, Rotek Incorporated has grown to become one of the world's recognized leaders in large-diameter slewing ring technology.

The company pioneered both the development of large-diameter slewing rings, and their introduction as a substitute for king post, hook roller and other older techniques for controlling loads in rotational applications. Over the years, Rotek has introduced the large-diameter slewing ring to a wide variety of applications, including power cranes and excavators, machine tools, medical equipment, large radar and radio telescope antennas, and wind turbines.

Rotek engineers have also been responsible for most of the product design innovations for large-diameter slewing rings, including the introduction of offset raceways, wire insert raceways, high speed slewing rings, and "quiet" slewing rings for medical applications.

Today, Rotek offers a diverse line of large-diameter slewing rings: ball and roller types in single-row and multiple-row configurations; with integral internal or external gearing, or gearless models; diameters from 12 inches to 50 feet; with a wide range of capacities, materials, and seals available. Many are available from stock or on short lead times. Rotek's diverse product line makes it possible to provide a large-diameter slewing ring that is most appropriate for your application, on the most cost-effective basis possible.



# Overview: Our Extensive Design Experience Provides Application Solutions

Rotek offers a unique combination of experience and technology in designing large-diameter slewing rings and seamless rolled rings. We've designed and manufactured thousands of slewing rings and rolled rings for a wide array of application requirements.

Our extensive experience combined with the use of sophisticated CAD/CAM technology enables us to accurately predict final product capabilities and performance. Our unique design capability is available on a no-charge basis to assist you



and your prospects during the slewing ring specification process. Our team of application and design engineers can perform a preliminary design evaluation based on your particular application requirements. This comprehensive analysis includes a study of slewing ring design parameters, static and dynamic load capacities, bolted joint design and gear design parameters, just to name a few.

You can rely on Rotek to create the product design that delivers the most effective solution for your application.

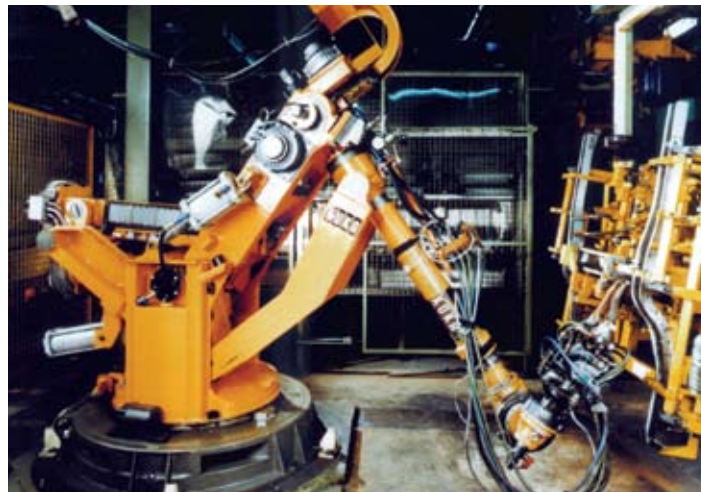

## Overview: Integrated Facilities Provide Complete Manufacturing Control

With fully integrated manufacturing facilities, including two North American slewing ring plants and two seamless ring rolling mills, Rotek is able to machine and assemble our products with complete control over quality and scheduling.

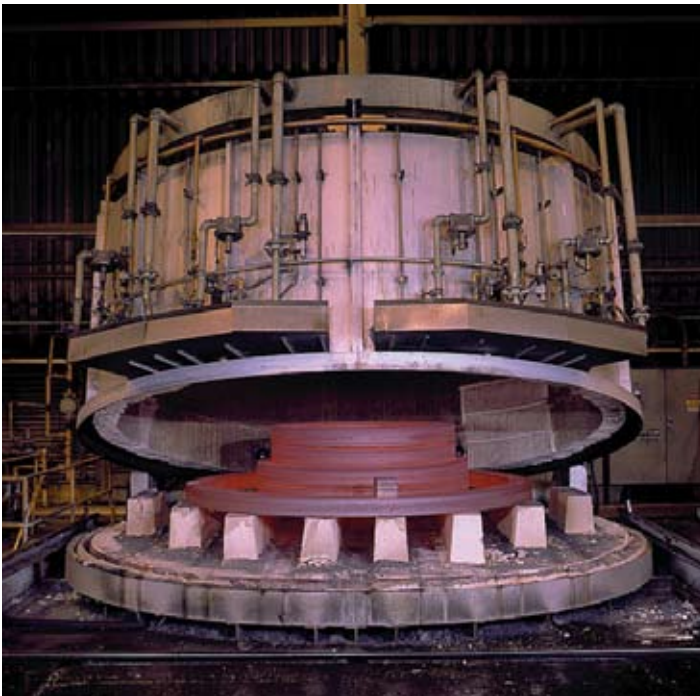

Large slewing ring production begins in our 180,000 square foot rolling mill facilities. Our rolling mills utilize advanced production technologies and equipment, including state-of-the-art presses and rolling mills, complete heat treating capabilities and value-added machining operations, as well as modern quality assurance and testing procedures.

Slewing ring production then continues at our slewing ring manufacturing facilities, located in Florence, Kentucky and Aurora, Ohio. Each facility utilizes advanced CNC



control technology, CAD/CAM technology and Total Quality Management disciplines to machine and assemble slewing rings to the highest quality standards.

### Worldwide Support

As an affiliate of Rothe-Erde, service is available virtually anywhere. With service facilities located in Germany, Brazil, Italy, Japan, China, India, Spain and Great Britain, our trouble-shooting network is ready to solve any ring problem you or your customer might have – wherever it may occur.

### Total Quality Management

Rotek's Quality Assurance system has been certified by Det Norske Veritas, a leading registrar, as complying with ISO 9001, and ISO 9002.

This TQM program and a continuous improvement policy keep our quality standards and procedures among the highest in the industry. Quality directs all aspects of our business, from procurement, to design and process control, to inspection and testing, to training and record keeping, to service and installation. Our commitment to quality assures our customers that the slewing rings we produce will perform well in their most challenging applications.



# Overview: Rotek Expertise Is Available After The Sale



Rotek offers a variety of after-the-sale services that can assist your staff in a variety of ways and can extend the service life of your slewing ring. Services include:

## **Installation/Change-Out Consultation and Supervision**

Proper slewing ring installation is vital. That is why we offer consultation services and on-site supervision for the installation or change-out of any new or replacement slewing ring. We can also advise you on the proper mounting structure to assure maximum slewing ring performance.

## **Preventative Maintenance Programs**

Rotek offers a contracted preventative maintenance program that provides regular inspection of your in-service slewing ring and the performance of scheduled maintenance procedures that can keep your slewing ring in peak condition and extend its service life.

## **In-Use Slewing Ring Analysis**

To further extend the service life of your slewing rings, we can perform an on-site analysis of their performance in their current application. This in-use evaluation includes non-destructive testing and component wear analysis, as well as further maintenance recommendations.

## **Service Life Analysis**

After your slewing rings have been removed from service, we can analyze wear patterns and make recommendations to improve service life.



# Product Line Summary



## Series 1000 Single Row Ball Slewing Ring

Series 1000 slewing rings are constructed with chrome-alloy steel balls with no spacers and steel rings with unhardened raceways. These slewing rings provide a cost-effective solution for applications requiring low-speed, bi-directional rotation of light loads.

### Specifications

RACEWAY DIAMETERS: 12" to 42"

#### CAPACITIES:

THRUST: 1650 to 35,200 pounds  
MOMENT: Not recommended for moment loads  
RADIAL: Contact Rotek

#### GEARING:

Furnished in gearless models only

#### APPLICATIONS:

Fifth wheels for trailers and farm vehicles

See page 40 for more information.

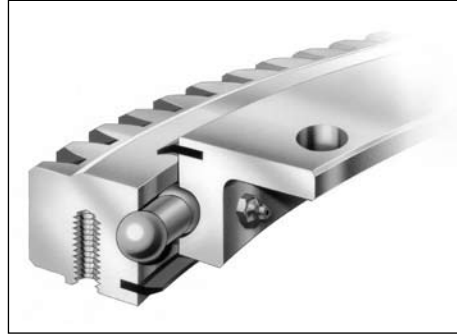

## Series 2100 Single Row Ball Slewing Ring

Series 2100 bearings are four-point contact slewing rings with induction-hardened, offset raceways. Balls are chrome-alloy steel and separated by spacers to prevent ball-to-ball sliding friction. Series 2100 slewing rings are general purpose slewing rings for medium to heavy-duty applications.

### Specifications

RACEWAY DIAMETERS: 13" to 57"

#### CAPACITIES:

THRUST: 7,000 to 1,100,000 pounds  
MOMENT: 1,400 to 390,000 foot-pounds  
RADIAL: 400 to 150,000 pounds

#### GEARING:

Gearless, internal or external gearing

#### APPLICATIONS:

Small cranes and excavators  
Industrial turntables  
Capstans  
Turnstiles  
Mining equipment

See page 42 for more information.

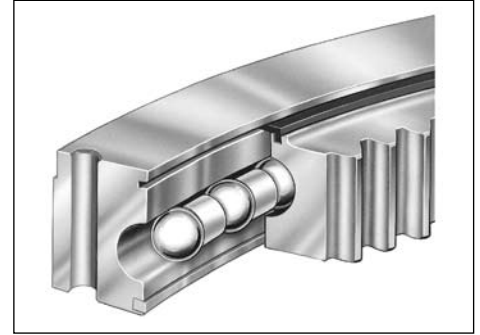

## Series 3000 Single Row Ball Slewing ring

Series 3000 slewing rings are an evolution of the classic four-point contact slewing ring design, featuring offset induction-hardened raceway construction, the highest degree of raceway wrap, and durable ball separators. Within the limits of their capacities, they offer an optimum combination of economy, reliability and durability.

### Specifications

#### RACEWAY DIAMETERS:

Standard models from 12" to 180"  
Special order bearings up to 360"

#### CAPACITIES:

THRUST: to 6,500,000 pounds  
MOMENT: to 21,000,000 foot-pounds  
RADIAL: to 1,200,000 pounds  
Contact Rotek for load information on special order models.

#### GEARING:

Gearless, internal or external gearing

#### APPLICATIONS:

Stationary and mobile cranes  
Excavators  
Stackers/reclaimers  
Lift truck rotators  
Industrial turntables  
Capstans  
Turnstiles  
Aerial lifts  
Mining equipment  
Forestry equipment

See page 50 for more information.

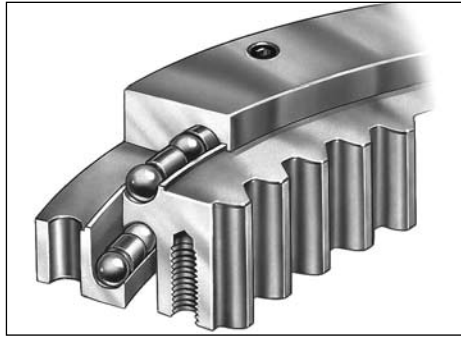

### Series 4000 Two Row Ball Slewing Ring

Series 4000 slewing rings are built with greater internal clearance than the Series 3000 model. Advantages include lower frictional torque and the ability to function in mounting structures with less accuracy and rigidity than required for other styles of slewing rings.

#### Specifications

RACEWAY DIAMETERS:  
Standard models from 12" to 180"

CAPACITIES:  
THRUST: to 8,700,000 pounds  
MOMENT: to 24,000,000 foot-pounds  
RADIAL: to 860,000 pounds

GEARING:  
Gearless, internal or external gearing

APPLICATIONS:  
Cranes and excavators  
Stackers/reclaimers  
Lift truck rotators  
Industrial turntables  
Capstans  
Turnstiles  
Mining equipment

See page 58 for more information.

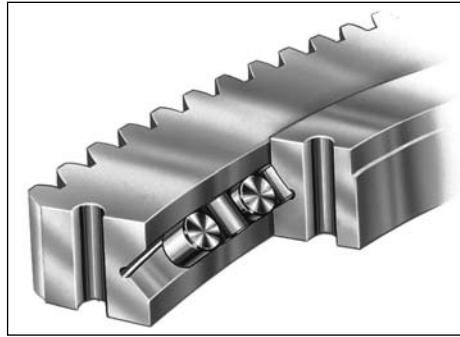

### Series 5000 Cross Roller Slewing Ring

Series 5000 slewing rings are built with V-groove raceways providing two roller paths in each ring. By alternating adjacent rollers at right angles to one another, one-half of the rollers transmit loads in one direction with the other half transmitting loads in the other direction. The cross roller slewing ring design provides a higher theoretical dynamic capacity per unit size, greater stiffness, and a lower spring rate, than a single row ball slewing ring design.

#### Specifications

RACEWAY DIAMETERS:  
Standard models from 12" to 180"

CAPACITIES:  
THRUST: to 4,600,000 pounds  
MOMENT: to 16,000,000 foot-pounds  
RADIAL: to 2,200,000 pounds

GEARING:  
Gearless, internal or external gearing

APPLICATIONS:  
Lift truck rotators  
Industrial turntables  
Mining equipment  
Machine tools  
Radar antennas  
Tunnel boring machines

See page 60 for more information.

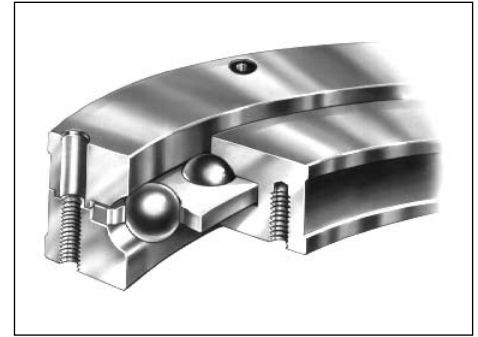

### Series 6000 High Speed Slewing Ring

Series 6000 slewing rings are single row, high-speed radial ball slewing rings, capable of raceway velocities of up to 3,000 feet per minute, with proper lubrication. These slewing rings feature exceptionally durable radial cages and are capable of sustained high-speed operation. High-speed operation requires selection based upon dynamic capacity limitations which impose more severe limits on loads than static capacity.

#### Specifications

RACEWAY DIAMETERS:  
Standard models from 12" to 180"

CAPACITIES:  
THRUST: to 1,000,000 pounds  
MOMENT: to 2,500,000 foot-pounds  
RADIAL: to 244,000 pounds

GEARING:  
Gearless, internal or external gearing

APPLICATIONS:  
Log-debarking machines  
Coil winders  
Pay-off reels  
High-speed capstans

See page 64 for more information.

# Product Line Summary

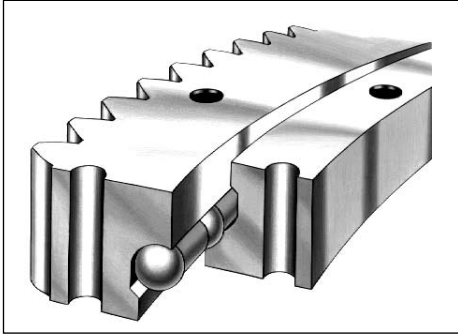

**Series 7100**  
**Vertical Thrust Slewing Ring**

Series 7100 slewing rings are single row ball slewing rings built for applications where the center of force remains within the slewing ring diameter under normal operating conditions. Thrust is transmitted at a 90° contact angle, thus making the most efficient use of the slewing ring capacity. Lift-off protection is provided to hold the assembly together under occasional uplifting loads.

### Specifications

#### RACEWAY DIAMETERS:

Standard models from 12" to 180"

#### CAPACITIES:

THRUST: to 1,290,000 pounds

MOMENT: Not applicable for moment loads

RADIAL: Contact Rotek

#### GEARING:

Gearless, internal or external gearing

#### APPLICATIONS:

Large turntables

Sewage and water treatment

Clarifiers, thickeners and rotary distributors

See page 66 for more information.

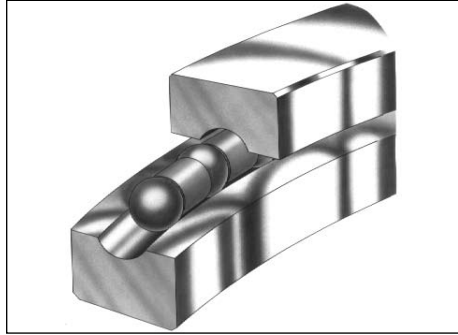

**Series 8000**  
**Vertical Thrust Slewing Ring**

Series 8000 slewing rings are single row ball slewing rings built for applications where the center of force remains within the slewing ring diameter under normal operating conditions. They offer the lowest cost per unit diameter for heavy pure thrust loads. No mounting holes or gearing is provided. Rings, raceways, ball and separators only.

### Specifications

#### RACEWAY DIAMETERS:

Standard models from 12" to 180"

#### CAPACITIES:

THRUST: from 60,000 pounds and up

MOMENT: Not applicable for moment loads

RADIAL: Contact Rotek

#### GEARING:

Available in gearless models only

#### APPLICATIONS:

Large turntables

Sewage and water treatment

Clarifiers, thickeners and rotary distributors

See page 66 for more information.

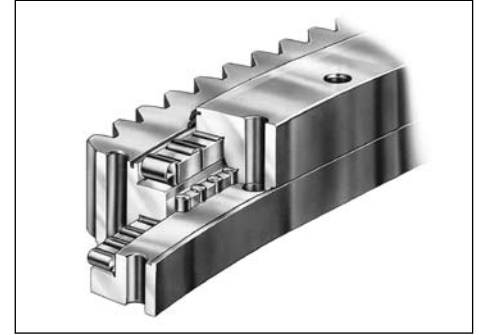

**Series 10,000**  
**Three Row Roller Slewing Ring**

Series 10,000 slewing rings are built with three independent rows of rollers. Since all loadings are transmitted directly to raceway surfaces which are perpendicular to the load direction, the capacity of each rolling element and each raceway surface is utilized in the most efficient manner. The three row roller slewing ring offers more capacity per unit size than any other Rotek design and is inherently the stiffest style of construction. Frictional torque is lower than other styles of Rotek bearings under most load conditions.

### Specifications

#### RACEWAY DIAMETERS:

Standard models from 12" to 180"

Special order bearings up to 360"

#### CAPACITIES:

THRUST: to 23,000,000 pounds

MOMENT: to 61,000,000 foot-pounds

RADIAL: to 2,500,000 pounds

Contact Rotek for load information on special order models.

#### GEARING:

Gearless, internal or external gearing

#### APPLICATIONS:

Off-shore cranes

Mooring buoys

Stacker/Reclaimers

Dockside cranes

Shipboard cranes

Ladle turrets

Crawler cranes

Excavators

Tunnel boring machines

Radar antennas

See page 68 for more information.

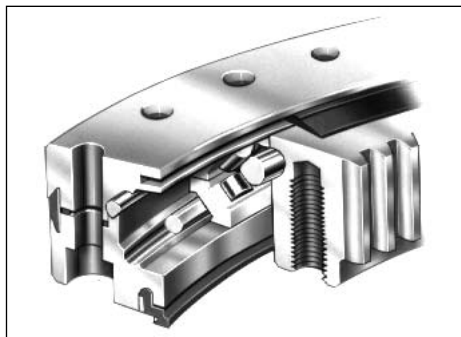

### Series 15,000 Wire-Race™ Slewing Ring

Rotek Wire-Race slewing rings are available in single row ball, two row roller and three row roller configurations. These slewing rings feature a replaceable, hardened, inserted wire raceway that allows supporting rings to be constructed in a variety of materials, including aluminum alloys and bronze. These slewing rings are ideal in applications where removal and replacement of the slewing ring would be difficult, where weight of the slewing ring is a critical consideration, and where ambient environment is corrosive to steel slewing ring materials.

#### Specifications

RACEWAY DIAMETERS: 12" to 600"

#### CAPACITIES:

THRUST: to 18,000,000 pounds  
MOMENT: to 700,000,000 foot-pounds  
RADIAL: to 2,000,000 pounds

#### GEARING:

Gearless, internal or external gearing

#### APPLICATIONS:

Radar antennas  
Medical equipment  
Any application where weight or corrosion is a concern, or where slewing ring replacement would be difficult

See page 72 for more information.

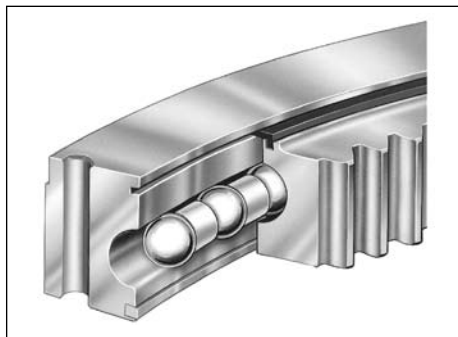

### Precision Slewing Rings

Rotek offers precision slewing rings in single row ball, cross roller and three row roller configurations. Depending on raceway diameter and slewing ring configuration, critical feature size and fit specifications can be held to the following ranges:

- Runout tolerances to within .0003"
- Concentricities to within .0003"
- Surface flatness to within .0003"
- Parallelism to within .0003"
- Bolt hole positions to .010" diameter
- Gear precision equal to or exceeding AGMA 10

#### Specifications

RACEWAY DIAMETERS: 12" to 180"

Contact Rotek about larger sizes

#### CAPACITIES:

Contact Rotek Application Engineering for information

#### GEARING:

Gearless, internal or external gearing

#### APPLICATIONS:

Precision turntables and index tables  
Robotics  
Medical diagnostic equipment  
Filling equipment  
Radar and radio telescope antennas  
Test stands and testing equipment

See page 76 for more information.

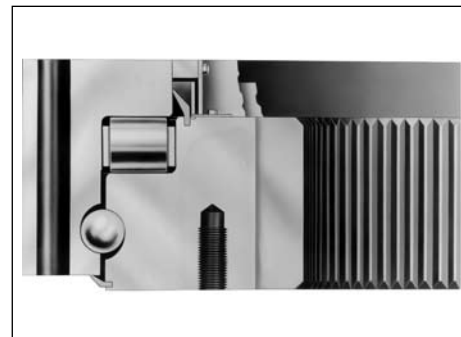

### Series 12,000 Roller/Ball Combination Slewing Ring

Series 12,000 slewing rings incorporate a row of balls and a row of rollers into the same slewing ring. This combination of rolling elements is designed to handle small eccentricities at relatively high axial loads.

#### Specifications

#### RACEWAY DIAMETERS:

Standard models from 12" to 250"  
Special order bearings up to 360"

#### CAPACITIES:

THRUST: up to 17,500,000 pounds  
MOMENT: up to 51,600,000 foot-pounds  
RADIAL: up to 775,000 pounds

#### GEARING:

Gearless, internal or external gearing

### Series 11,000 Single Row Ball Slewing Ring

Series 11,000 slewing rings are constructed with aluminum rings and plastic ball bearings to provide an economical slewing ring for light load applications requiring a low-friction, lightweight, corrosion-resistant slewing ring.

#### Specifications

#### RACEWAY DIAMETERS:

Standard models from 12" to 60"

#### CAPACITIES:

THRUST: up to 4,000 pounds  
MOMENT: Contact Rotek  
RADIAL: Contact Rotek

#### GEARING:

Gearless, internal or external gearing

⚠ Series 12,000 and Series 11,000 bearings are non-cataloged products. Contact Rotek at 800/221-8043 for more information.

# Table of Contents

## Engineering Section

13	<u>Engineering Section Introduction</u>
13	<u>Load Transmission Characteristics</u>
14	<u>Slewing Ring Loads Defined</u>
14	<u>Determining Slewing Ring Loads</u>
15	<u>Sample Loading Types</u>
16	<u>Slewing Ring Types</u>
17	<u>Raceway Hardening</u>
18	<u>Raceway Capacity</u>
19	<u>Application Service Factors</u>
20	<u>Bolt Capacity</u>
21	<u>Bolting Assumptions</u>
22	<u>Bolt Preload Information</u>
23	<u>Additional Bolting Information</u>
24	<u>Turning Torque Calculations</u>
25	<u>Gear Capacity</u>
26	<u>Gearing</u>
28	<u>Pinion Tip Relief</u>
29	<u>Companion Structures</u>
30	<u>Permissible Out-of-Flatness and Deflection in Companion Structures</u>
31	<u>Radial Slewing Ring Deflections</u>
32	<u>Wear Measurement</u>
34	<u>Set-up Information</u>
35	<u>Lubrication and Maintenance</u>
36	<u>Operating Conditions and Special Requirements</u>
37	<u>Slewing Ring Design Worksheet Instructions</u>
38	<u>Slewing Ring Design Worksheet</u>

## Engineering Section Introduction

This section of the catalog provides engineering information to assist you in the selection and specification of large-diameter slewing rings. A slewing ring design worksheet, beginning on page 37, is included to allow us to assist you in the process.

We encourage you to contact our Application Engineering Department at the outset of your design program. Our expertise in slewing ring design and use of CAD technology can be used to accurately predict final product capabilities and performance.

Our expertise is available to you on a no-charge basis. We will provide a preliminary design evaluation based on your specific application requirements. This comprehensive written analysis generally includes a review of slewing ring design parameters, static and dynamic load capacities, bolt requirements and suggested gear specifications, just to name a few.

☎ To start the design process, or for more information on any aspect of Rotek's capabilities, contact your local Rotek sales representative or the Rotek Application Engineering Department at 330/562-4000 or toll-free at 800/221-8043.

## Load Transmission Characteristics

A Rotek slewing ring is a complete, ready-to-use package. It is an engineered system of balls or rollers, spacers or cages, raceways, mounting provisions, and integral gearing. It needs simply to be bolted in place to be operational.

Many Rotek large-diameter slewing ring models are designed to transmit all combinations of axial, radial and tilting moment loads. This combination load capacity is achieved in one assembly, eliminating the weight, space and cost penalties of other rotational designs.

It is recommended that Rotek slewing rings be mounted to a suitable supporting companion structure. It is essential that the companion structure be built to appropriate specifications to minimize slewing ring distortion and extend service life. See page 29 for details.

A Rotek slewing ring may be utilized in applications where loads will be suspended from the slewing ring, but special considerations regarding the type and number of fastening bolts are required for these types of applications.

☎ We require that Rotek be consulted for assistance in the specification of slewing rings for suspended load applications.

### Slewing Ring Loads Defined

Slewing ring loads are defined in terms of one or a combination of axial, radial and moment loads.

An axial load is a load that acts parallel with the axis of rotation. Figure 1 shows a compressive axial load application. A compressive axial load will squeeze mounting surfaces together while a tensile axial load acts to pull the slewing ring away from the supporting structure. A compressive axial load is commonly referred to as a thrust load. A tensile axial load may be referred to as either a tension load or a hanging load. Tension loads are not possible without mounting fasteners. Applications involving tensile axial loads are subject to special design criteria. Rotek should be consulted for such cases.

A radial load is a load that acts perpendicular to the axis of rotation. A radial load is often referred to as a side or shear load. Figure 3 shows a radial load application. In the bolted connection, radial loads are resisted by the frictional holding power of the clamped interface. Precision cylindrical pilots or dowels are sometimes incorporated to transmit high radial loads.

A moment load, or “overturning” moment load, acts about a line perpendicular to the axis of rotation. A moment load induces thrust on one half of the slewing ring and tension on the other half. Moment loads result from an axial load applied at a distance from the axis of rotation (Figure 2), a radial load applied at a perpendicular distance from the plane of the slewing ring (Figure 4), or a combination of both axial and radial effects (Figure 5).

A single slewing ring load condition consists of all axial, radial, and moment load components which occur simultaneously. Most loading situations can be adequately defined in two dimensions (such as in Figures 1 through 6).

Others may require three dimensions to properly consider the loads.

It is important that only axial, radial and moment load components which act simultaneously are defined within a slewing ring load case. While a consolidation of “worst case” loading components into a single load case may be thought of as a conservative way to simplify a slewing ring selection, it can have the adverse effect of an inadequate slewing ring selection!

### Determining Slewing Ring Loads

Slewing ring loads may be easily determined using a classical engineering approach of creating Free-Body Diagrams and then solving for the unknown variables using equations of static equilibrium.

A Free-Body Diagram is a sketch showing forces, their vectorial direction in terms of X & Y Cartesian coordinate values, and X & Y perpendicular distances of these forces relative to the center of the slewing ring.

The slewing ring plane becomes a cut line for the Free-Body Diagram dividing forces left and right (Figure 4) or top and bottom (Figure 2) relative to the slewing ring plane. Slewing ring loads are simply the reaction forces at the cut plane.

Equations of static equilibrium are used to solve for the reactionary forces at the cut plane. These equations are:

$$\begin{aligned}\Sigma \text{ Axial Forces} &= 0 \\ \Sigma \text{ Radial Forces} &= 0 \\ \Sigma \text{ Moments} &= 0\end{aligned}$$

The  $\Sigma$  symbol indicates that all loads are added, or summed, together. The directions of force and moment rotation are very important in these equations and indicates whether a value is taken as positive or negative. Moment loads are calculated about the center of the slewing ring (where the center plane and rotation axis of the slewing ring cross).

Figures 1 through 6 are examples of Free-Body Diagrams simplified to show the final results of solving the equilibrium equations.

Additional methods and examples of using Free-Body Diagrams and equations of static equilibrium to solve for reaction forces can be found in many engineering texts and handbooks.

### Example:

Our example application is for a fixed, pedestal mounted lift. Figure 6 shows a Free-Body Diagram (FBD) for this slewing ring application. It is important that the FBD show the direction of force and the distance of each center of gravity to the center of the slewing ring. It is not necessary that the FBD be a detailed picture of the application.

This FBD assumes that the machine is level so that gravity produces no radial load. This FBD assumes that there are no wind induced side radial or moment loads. This FBD also assumes that gear separating forces result in negligible radial load.

The slewing ring provides a cut plane for the FBD. All loads above the slewing ring plane must be transmitted by the slewing ring for equations of static equilibrium to be satisfied. These equations are generically solved and shown to the right of the FBD in Figure 6. The following coordinate forces and distances are known:

$$\begin{aligned}A &= 32000 \text{ lbs. @ } a = 10 \text{ ft} \\ B &= 2000 \text{ lbs. @ } b = 8 \text{ ft} \\ C &= 3000 \text{ lbs. @ } c = 4 \text{ ft} \\ Z &= 24000 \text{ lbs. @ } z = 3 \text{ ft}\end{aligned}$$

Slewing ring loads are then solved:

$$\begin{aligned}\text{Axial Thrust Load, } F_A &= 32000 \text{ lbs.} \\ &+ 2000 \text{ lbs.} + 3000 \text{ lbs.} + 24000 \\ &\text{lbs.} = 61000 \text{ lbs. } \checkmark\end{aligned}$$

$$\text{Radial Load, } F_R = 0 \text{ lbs. } \checkmark$$

$$\begin{aligned}\text{Moment Load, } M_K &= (32000 \text{ lbs.}) \\ &(10 \text{ ft}) + (2000 \text{ lbs.})(8 \text{ ft}) + (3000 \\ &\text{lbs.})(4 \text{ ft}) - (24000 \text{ lbs.}) \\ &(3 \text{ ft}) = 276000 \text{ ft-lbs. } \checkmark\end{aligned}$$

Figure 1  
Thrust  
Loading

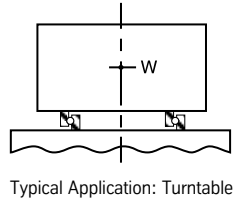

W = Weight (lbs.)  
Thrust Load = W (lbs.)  
Moment Load = 0  
Center of gravity coincides with center of rotation.

Figure 2  
Thrust Loading  
and Moment  
Loading

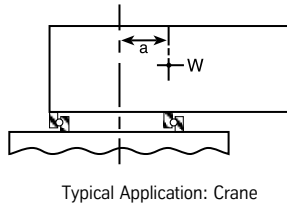

W = Weight (lbs.)  
a = Distance from center of gravity to center of rotation (ft.)  
Thrust Load = W (lbs.)  
Moment Load = W x a (ft-lbs.)  
Center of gravity does not coincide with center of rotation.

Figure 3  
Radial  
Loading

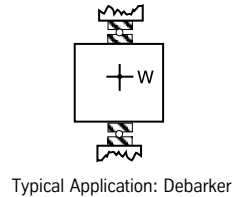

W = Weight (lbs.)  
Thrust Load = 0  
Moment Load = 0  
Radial Load = W

Figure 4  
Radial Loading  
and Moment  
Loading

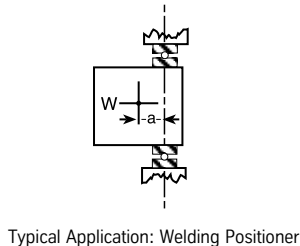

W = Weight (lbs.)  
a = Distance from center of gravity to plane of rotation (ft.)  
Moment Load = W x a (ft-lbs.)  
Radial Load = W (lbs.)

Figure 5  
Combined  
Loads

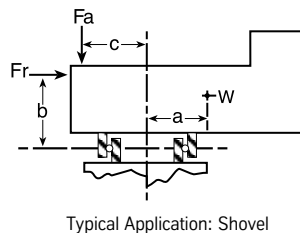

W = Weight (lbs.)  
a = Moment Arm (ft.)  
Fa and Fr = External Forces (lbs.)  
b and c = Moment Arms (ft.)  
Thrust Load = W + Fa  
Radial Load = Fr  
Moment Load = Wa + Frb - Fac

Figure 6  
Sample  
Calculation

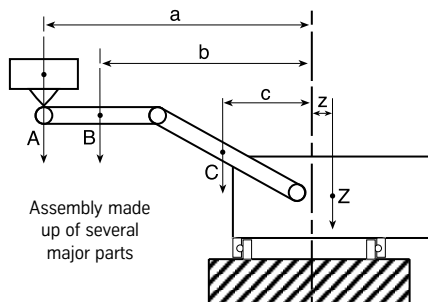

A = Weight of load and box (lbs.)  
a = Distance from center of gravity of A to center of rotation (ft.)  
B = Weight of boom section "B" (lbs.)  
b = Distance from center of gravity of B to center of rotation (ft.)  
C = Weight of boom section "C" (lbs.)  
c = Distance from center of gravity of C to center of rotation (ft.)  
Z = Weight of structure Z (lbs.)  
z = Distance from the center of gravity of Z to center of rotation (ft.)  
Thrust Load = A + B + C + Z (lbs.)  
Moment Load = Aa + Bb + Cc - Zz (ft-lbs.)

(Net Moment Load always equals the difference between clockwise and counterclockwise moments.)



### Slewing Ring Types

After loads have been calculated, refer to the Product Line Summary on pages 8 through 11. This summary presents basic data for choosing one or more styles of slewing rings for your application.

Series 1000 slewing rings were developed for use as “fifth-wheel” bogie steering pivots on trailer applications. With certain constraints, some Series 1000 slewing rings have also been applied to turntable applications.

Series 2100 slewing rings are the most popular choice for general turntable applications. Their moment capacity provides stability to turntables having diameters well in excess of the slewing ring diameter. They also serve the need of other applications requiring combination-load slewing ring capabilities. Series 2100 slewing rings are characteristically larger in diameter than Series 3000 slewing rings of same capacity. If a large diameter is desirable, Series 2100 slewing rings are usually the economical choice within their catalog size and capacity ranges.

Series 3000 slewing rings are the most popular of all Rotek slewing rings built and are offered in the broadest variety. In a majority of applications, they offer an optimum combination of capacity, durability and economy. A variety of slewing rings are in regular production and are available for prompt delivery. Custom models to satisfy exact design requirements are routine.

Series 4000 slewing rings are favored for applications where minimum friction is required. They have somewhat greater internal clearance than comparable Series 3000, 5000 and 10000 models. Mounting structure requirements are not as critical. Cost is typically more than Series 2100, 3000 and 5000 types of comparable capacity.

Series 5000 slewing rings are ideally suited to applications where extreme stiffness is required. They are typically used in machine tools, radar antennas and optical equipment. A flat and rigid mounting structure is essential for optimum performance.

Series 10000 slewing rings offer the highest capacity per unit size of any Rotek slewing ring. They are used principally for higher loads, although smaller models overlap Series 3000, 4000 and 5000 capacities. As with Series 5000 roller slewing rings, a flat and rigid mounting structure is critical for the proper transmission of slewing ring loads. Generally, Series 10000 models are substantially more costly than Series 3000 and 5000 models for capacity ratings under 2 million foot-pounds.

Series 6000 slewing rings are popular designs for high-speed applications. Consult Rotek for specific recommendations and slewing ring selection.

Series 7100 slewing rings have high contact angles and increased internal clearance making them an ideal selection for thrust applications where the center of force remains within the raceway diameter. Lift-off protection allows the slewing ring to ship and mount as a self-contained package. Gearing is available. Friction is low.

Series 8000 slewing rings are used for thrust applications and can be less costly than equivalent 7100 series models. They do not provide integral gearing nor lift-off protection. If neither feature is required, Series 8000 models provide an economical thrust slewing ring choice.

Note: Series 7100 and 8000 slewing rings are not regularly produced in substantial quantities, so a high-production Series 3000 model may prove to be more

economical for small quantity applications.

With the exception of Series 1000 slewing rings, most of the previously mentioned slewing rings series are also available as precision slewing rings with very precise tolerances. Production of very tight tolerances involves substantial added cost, producing price levels as much as two to three times those of standard heavy-duty slewing rings. Contact Rotek for specifics.

Rotek Series 15000 Wire-Race slewing rings are famous for their light weight and high reliability. They have been used throughout the world in medical scanning equipment and radar antennas. They may be appropriate where light weight, replaceable raceways or slewing ring material selection is an important consideration. Rotek does not recommend any attempt at self-selection. Rather, we recommend that you call us for assistance early in your design process.

Rotek also markets several lines of highly specialized slewing rings. Call for additional information and assistance on Series 11000 plastic ball slewing rings, Series 12000 combination ball/roller slewing rings, high-temperature slewing rings for applications up to 375°F and our line of high-speed “Whisper” slewing rings.

## Raceway Hardening

Most slewing ring types described in this catalog are provided with induction-hardened raceways. This ensures good reproducibility of hardening specifications and, therefore, consistent quality. The hardening coils used have been adapted to the various raceway designs. They are configured so as to guarantee the load capacities specified for the respective rolling element sizes.

Our coil shapes ensure a good hardness pattern in the raceways and in the transition radii in three-row roller slewing rings.

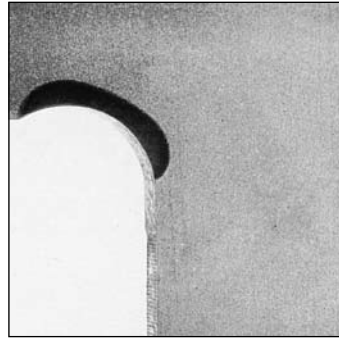

Figure 7: Raceway of a supporting ring in a double-row ball slewing ring.

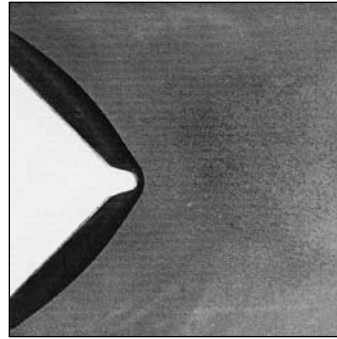

Figure 8: Raceways in a single-row roller slewing ring.

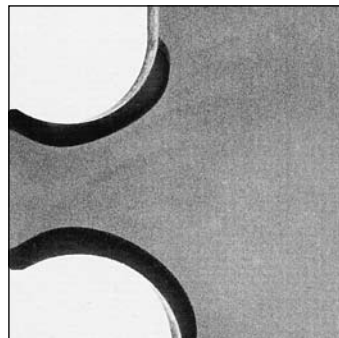

Figure 9: Raceways of a nose ring in a double row ball slewing ring

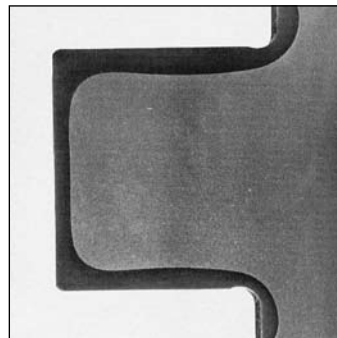

Figure 10: Raceways of a nose ring in a three-row roller slewing ring

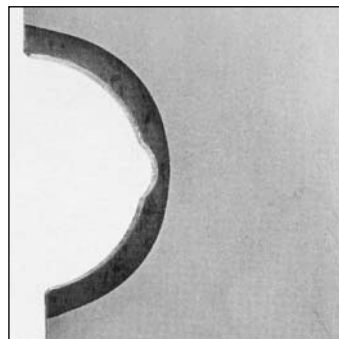

Figure 11: Raceways in a single-row ball slewing ring

### Raceway Capacity

The raceway capacities listed in this catalog are static capacity ratings. Since most Rotek large diameter slewing ring applications involve intermittent slewing and a broad spectrum of loads, it is customary to select a slewing ring based on its static capacity and a recommended application service factor.

Capacities listed in this catalog are non-simultaneous. In other words, a catalog thrust capacity assumes that there is thrust load only with zero moment and zero radial load. In the same way, moment capacity assumes no thrust or radial load. Radial capacity assumes no thrust or moment load.

When applications involve a combination of any thrust, moment or radial load, the load components must be combined into an equivalent load. For static slewing ring calculations, this equivalent load is taken to be load as seen by the highest loaded rolling element. At the right are equations for calculating equivalent thrust loads for many slewing ring types.

For many slewing ring types, the radial load can be ignored as long as it does not exceed 5% of the thrust loading. However, if the radial load is applied at any point other than the center plane of the slewing ring, the resulting tilting moment must be calculated and included in the slewing ring selection.

Slewing ring load capacity charts are a visual representation of the slewing ring load equations assuming that (except as noted) the radial load component equals zero. Series 2100 models require the use of load capacity charts.

Capacity ratings listed in this catalog represent a raceway service factor of 1.00. For adequate service life, a proper application service factor must be employed.

### Checking the Raceway Capacity of a Specific Slewing Ring Design

After slewing ring loads have been calculated and the type of slewing ring has been selected, the raceway capacity of a specific model may be checked according to the following procedure:

1. Approximate the raceway diameter,  $D_L$  (in inches) using the number directly after the dash in the slewing ring model number. **Example:** If internally geared 3000 Series model A10-35N1L has been selected, then  $D_L = 35$  inches based on the slewing ring model number.
2. Approximate the Equivalent Thrust Load, ETL, (in pounds) for the support slewing ring row using the following equation:

$$ETL = \frac{(12)(k)(M_K)}{D_L} + F_A + (k_R)(F_R), \text{ where}$$

$F_A$  = Axial Thrust Load [lbs]

$M_K$  = Moment Load [ft-lbs]

$F_R$  = Radial Load [lbs]

For 3000 Series models,  $k=4.37$  and  $k_R = (4.37) (\tan \alpha)$

Where  $\alpha$  typically equals  $45^\circ$ ,  $53^\circ$  or  $60^\circ$ . ☛ Contact Rotek for details.

For 4000 Series models,  $k=4.37$  and  $k_R = 0$

For 5000 Series models,  $k=4.10$  and  $k_R = 2.05$

For 6000 Series models,  $k=4.37$  and  $k_R = 4.37$

For 10000 Series models,  $k=4.10$  and  $k_R = 0$

Series 1000, 7100 and 8000 Series are thrust models. ☛ If the worst case load is not completely centered, contact Rotek for assistance in calculating an equivalent thrust load.

Series 2100 models require use of the catalog curves.

**Example:** (using loads calculated on page 14):

$$ETL = \frac{(12)(4.37)(276000 \text{ ft-lbs})}{35} + 61,000 \text{ lbs} + (7.57)(0) = 474527 \text{ lbs.}$$

3. Calculate the raceway service factor, RWSF, using the slewing ring thrust capacity,  $A_0$ , noted in the catalog listing:

$$RWSF = \frac{A_0}{ETL}, \text{ where } A_0 = \text{catalog thrust capacity}$$

**Example:**  $RWSF = \frac{749000 \text{ lbs}}{474527 \text{ lbs}} = 1.58 \checkmark$

4. For multi-row Series 4000 and 10000 models only, calculate the equivalent moment load,  $EML_{RET}$ , (in foot-pounds) and the raceway service factor,  $RWSF_{RET}$ , for the smaller, retaining race:

$$EML_{RET} = M_K + \frac{D_L}{(12)(k)} [(k_R)(F_R) - F_A], \text{ where}$$

For 4000 Series model,  $k = 4.37$  and  $k_R = \checkmark$  Contact Rotek

For 10000 Series models,  $k = 4.10$  and  $k_R = 0$

$$RWSF_{RET} = \frac{M_0}{EML_{RET}}, \text{ where } M_0 = \text{Moment raceway capacity}$$

5. For Series 10000 three-row-roller bearing only, calculate the raceway service factor,  $RWSF_{RAD}$ , of the radial race row:

$$RWSF_{RAD} = \frac{R_0}{F_R}, \text{ where } R_0 = \text{Radial raceway capacity}$$

6. ☛ Confirm all selections with Rotek

Note: In continually revolving or high use applications, dynamic capacity, not static capacity, may govern the selection. Such applications require additional, separate calculations. ☛ Contact Rotek for details.

## Application Service Factors

Rotek slewing rings are applied in a wide range of applications. Table 1 lists recommended minimum raceway service factors for a variety of slewing ring applications and classifications of service. For reasonable service life, it is imperative that a proper raceway service factor be chosen.

Raceway service factors should be applied against maximum operating or rated loads. If high reliability is required, it is obviously desirable to choose conservatively. In some cases, it may be practical to construct a prototype machine and conduct accelerated life testing to confirm the choice of a less conservative slewing ring.

The exact duty cycle of the machine and the design of the mounting structure will have tremendous influence on the durability of the slewing ring. It should be clear that the raceway service factors of Table 1 assume that the slewing ring will be properly supported and maintained.

In high cycle applications, dynamic capacity, rather than static capacity, may govern the slewing ring selection. In those cases separate calculations must be made and Rotek should be contacted. ☎

### Selecting a Raceway Service Factor for a Specific Slewing Ring Design

Example: The A10-35N1L slewing ring is to be used for a pedestal mounted lift. Usage is intermittent but not well defined. The slewing ring loads calculated on page 16 are for the maximum rated lift condition. Using Table 1, a minimum raceway service factor,  $RWSF_{MIN}$  of 1.45 is selected.

From the example on the previous page, the calculated  $RWSF = 1.58$ .  $\checkmark$  Raceway capacity is suitable since the calculated  $RWSF$  exceeds  $RWSF_{MIN}$ .

**Table 1: Raceway Service Factors For Various Applications**

Class of Service	Description of Service	Typical Applications	Recommended Minimum Service Factor	Method of Computing Nominal Slewing Ring Loads
Extreme Duty	Machine capacity not well defined — or — Loads beyond machine capacity can occur — or — Heavy shock loading can occur.	Hydraulic Excavator (over 75,000 lbs.) Steel Mill Machinery Logging Equipment	1.75	If machine loading is limited by possible machine tipping, compute maximum bearing load which occurs at tipping — or — If machine loading is not limited by possible tipping, compute load based on maximum possible line pull, maximum hydraulic pressure, or other reliable determinant of maximum static slewing ring load.
		Floating Cranes Magnet Cranes Charging Cranes Steel Mill Cranes Stacker/Relaimer Hook Rotators Crab-type Gantry Cranes	1.45	
		Manipulators Hydraulic Excavators (under 75,000 lbs.)  Misc. Oil Field Machinery Stripper Cranes Pedestal Cranes Overhead Grab Cranes		
	Machine capacity well defined. Machine may be operated 8 hrs. per day or more.	Stripping Cranes Tower Cranes (*) Overhead Cargo Cranes Ship Unloader Front Loader Clam Shell Cranes Drag Lines Crawler Cranes Railway Cranes	1.25	Compute highest slewing ring loading resulting from rated machine capacity.
Intermittent Service	Machine capacity well defined. Full capacity seldom used or slewing ring seldom rotated more than one hour per day.	Mobile Cranes Harbor (Shipyards) Cranes Shipdeck Cranes Fire Equipment Digger Derricks Sticker Cranes Conveyors	1.10	(*) Indicates that the dynamic capacity may govern the slewing ring selection.  In many of the above applications, the dynamic capacity should be verified using Rotek's extensive application experience. Please contact Rotek Engineering for additional information.
		Fork Truck Roators Turntables (*) Utility Cranes  Weld Positioners Aerial Baskets  Water Treatment Sewer Equipment (*) Machine Tables (*) Capstans (*) Instruments (*)	1.00	

## Bolt Capacity

In many cases slewing ring moment capacity is limited by the capacity of the mounting bolts rather than the capacity of the slewing ring races.

Below is a chart to assist in a preliminary check of the mounting bolt capacity for normal applications. See page 21 for assumptions. The chart below is not valid for Series 2100 slewing rings. See pages 44-45.

☞ Contact Rotek for a detailed bolt analysis using advanced computer-based techniques.

In extreme cases it may be necessary to strain-gage the bolts and measure the actual bolt loads under maximum applied static loads on a prototype machine to verify the suitability of a given bolt design.

**CAUTION:** Unless specifically noted otherwise, moment and radial capacities listed in this catalog refer to the capacity of the raceways, not the capacity of the mounting bolts.

### Using the Bolt Design Chart To Check a Specific Slewing Ring Design

1. The required bolt clamping capacity,  $BCC_{REQ}$ , may be calculated using the following equation:

$$BCC_{REQ} = \frac{(12)(k)(M_K)}{D_L} - F_A$$

The same values and units of  $K$ ,  $F_A$ ,  $M_K$  and  $D_L$  as used for the raceway calculations (on page 18) should be used for this calculation.

Example (using loads calculated on page 14):

$$BCC_{REQ} = \frac{(12\text{in/ft})(4.37)(276000\text{ ft-lbs})}{35\text{ inches}} - 61000\text{ lbs} = 352527\text{ lbs}$$

2. Use the Bolt Design Chart below to approximate the required number of equally spaced bolts based on the value of  $BCC_{REQ}$  and the slewing ring fastener size.

Example: A10-35N1L uses 3/4-10UNC bolts. For  $BCC_{REQ} = 352527\text{ lbs}$ , 27 equally spaced bolts are required for this bolt size per the chart below.

3. Calculate a bolt clamping factor, BCF. The bolt clamping factor must equal or exceed 1.0.

$$BCF = \frac{\text{Number of Equally Spaced Bolts Used}}{\text{Number of Equally Spaced Bolts Required}}$$

Example: A10-35N1L has 30 equally spaced bolts per race. 27 bolts are needed.  $BCF = 30 \div 27 = 1.11$ . ✓ Approximated bolt capacity is okay since BCF is greater than 1.0.

4. ☞ Confirm all selections with Rotek.

## BOLT DESIGN CHART

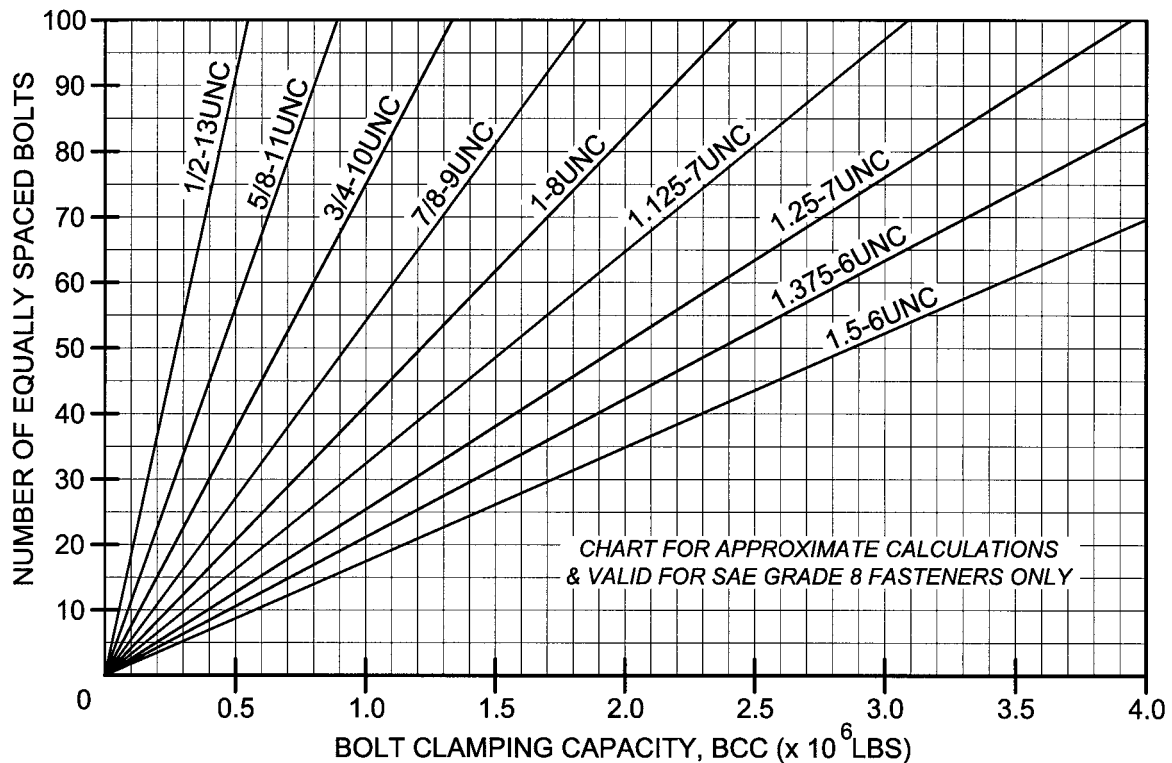

## Bolting Assumptions

To achieve good service life of a large-diameter slewing ring, all fastening bolts must be adequately sized and carefully preloaded. In our Research and Development Department we systematically test and measure bolted slewing ring connections to quantify the factors that influence the bolted joint.

The primary influential factors which have been deduced from these test results are incorporated into computer calculation programs. These calculations are run by the Rotek Application Engineering department on a no-charge basis to our customers. Bolt curves given in this catalog are supplied for guidance only. All bolt calculations should be checked by Rotek Engineering.

For Rotek's bolt calculations to be valid, the following conditions must normally apply:

- a) The axial load  $F_a$  acts as compression load, i.e. the axial operating force  $F_a$  resulting from the axial load does not subject the bolts to tensile stress (compare Figures 12 and 13).
- b) The bolts are equally spaced on the bolt hole circles.
- c) The companion structures meet our technical requirements (see page 29).
- d) The slewing ring and companion structures are made of steel.
- e) Cast resin grouting is not used in mounting the slewing ring.
- f) The clamping length is at least  $5 \cdot d$  for slewing rings with a complete ring cross section and at least  $3 \cdot d$  for profiled rings, such as Series 2100 (with  $d$  being the bolt diameter). Smaller clamping lengths are more sensitive to loss of preload; such bolt connections must therefore be checked at more frequent intervals. Poor slewing ring load distribution may also occur if small clamping lengths are used, resulting in binding and or short raceway life.

g) There are at least six free threads in the loaded part of the bolt.

☞ If the above assumptions are not the case, Rotek must be consulted

Accurate load data is imperative for meaningful bolt calculation results. Recognize that a load case critical to the slewing ring selection based on raceway capacity may not be the same as the load case critical to a selection based on bolt capacity. All critical load cases must be checked.

The support surface and thread axis for the mounting fasteners must be at right angles.

In the absence of pilots, the radial load is transmitted proportionately at the slewing ring/structure interface by friction resulting from the clamping force of the bolts.

It is very important that the selected slewing ring remains clamped against its supporting structure at all times. Sizing fasteners by this method according to Rotek's bolt calculation assumptions results in a reasonable safety factor against ultimate bolt failure. However, the absence of a bolt failure alone does not indicate proper clamping. Without proper clamping, raceway capacity is compromised and slewing ring longevity is reduced.

It is assumed that fasteners will be pre-tensioned by reliable means and that bolt tension will be checked and maintained over the life of the slewing ring. Installation and maintenance instructions are found on pages 34-35. Access holes should be provided as necessary to check and maintain bolt tightness in the field.

Rotek's bolt calculation method has proven to be reliable for thousands of slewing ring applications. However, there are numerous, unique factors that exist that can adversely influence the bolted joint connection which

are either unknown or beyond the scope of practical evaluation in a slewing ring selection. Therefore, Rotek strongly encourages testing of the fastened bolts prior to releasing new equipment into the marketplace.

The chosen fastener type and strength class must be guaranteed by the supplier. Look for labeling to DIN, SAE or ISO standards.

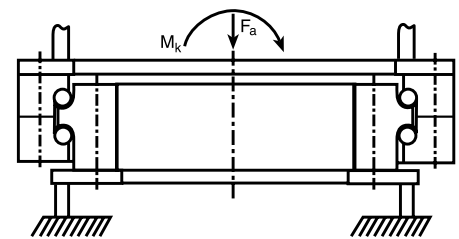

Figure 12: "Supported" axial load Bolt tension results from  $M_k$  only.

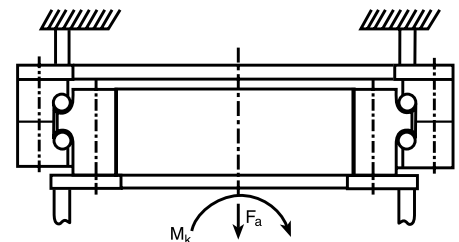

Figure 13: "Suspended" axial load Bolt tension results from  $M_k$  and the suspended load.

### Bolt Preload Information

Table 2 gives guidance values for clamping loads for bolts up to 2-1/2" and tightening torque for bolts up to 1-1/4". No tightening torques are given in Table 2 for fasteners larger than 1-1/4" as our experience shows that the frictional values vary too greatly. It is better to use a hydraulic bolt tensioner for these bolts.

Fasteners should be torqued to achieve a clamp load up to 70% of the load it takes to yield a bolt under pure tension. Preloading beyond this 70% value is not recommended if fasteners are torqued since torsional stresses must also be considered in a combined stress state.

Hydraulic bolt tensioners preload fasteners by pure axial forces only. Fasteners preloaded by means not inducing torsional stresses may be preloaded to a clamp load up to 90% of the bolt's yield point.

When specifying a bolt preload value, either in terms of clamp load or mounting torque, take into account the accuracy of the tightening method and the tightening device to maximize pretensioning without exceeding the design clamp load. The nominal reference mounting torque values in Table 2 allow for a variation of  $\pm 10\%$ .

Tightening torque will depend on several factors, especially the friction value in the thread and at the bolt head or nut contact surface. Torque values given in Table 2 assume a mean coefficient of friction of 0.14 at these interfaces. Due to the many influencing factors, torque values are presented for reference only. We strongly urge that sample tests be made to establish specific torque values.

Reference pages 34-35 for mounting fastener installation and maintenance instructions.

**Table 2: Clamping Forces and Tightening Torques**

Bolt Size	Tensile Area (sq. in.)	ASTM A-490/Grade 8 (130,000 psi yield)			Nominal Ref. Mtg. Torque (ft-lbs)
		Clamp Load at 90% Yield (lbs.)	Clamp Load at 70% Yield (lbs.)	Torque Ref. at 70% Yield (ft-lbs)	
1/4-20 UNC	0.0318		2,894	11	10
5/16-18 UNC	0.0524		4,768	24	22
3/8-16 UNC	0.0775		7,053	42	38
7/16-14UNC	0.1063		9,673	67	60
1/2-13 UNC	0.1419	16,602	12,913	102	92
9/16-12 UNC	0.182	21,294	16,562	147	132
5/8-11 UNC	0.226	26,442	20,566	204	184
3/4-10 UNC	0.334	39,078	30,394	361	325
7/8-9 UNC	0.462	54,054	42,042	582	524
1-8 UNC	0.606	70,902	55,146	873	786
1 1/8-7 UNC	0.763	89,271	69,433	1,237	1,113
1 1/4-7 UNC	0.969	113,373	88,179	1,745	1,571
1 3/8-6 UNC	1.155	135,135	105,105		
1 1/2-6 UNC	1.405	164,385	127,855		
1 3/4-5 UNC	1.90	222,300	172,900		
2-4.5 UNC	2.50	292,500	227,500		
2 1/4-4.5 UNC	3.25	380,250	295,750		
2 1/2-4 UNC	4.00	468,000	364,000		
Bolt Size	Tensile Area (sq. in.)	DIN 10.9 (136,335 psi yield) fasteners			Nominal Ref. Mtg. Torque (ft-lbs)
		Clamp Load at 90% Yield (lbs.)	Clamp Load at 70% Yield (lbs.)	Torque Ref. at 70% Yield (ft-lbs)	
M5 x 0.8	0.0220		2,101	6.6	5.9
M6 x 1	0.0312		2,973	11.4	10.3
M8 x 1.25	0.0567		5,414	27	25
M10 x 1.5	0.0899		8,580	55	50
M12 x 1.75	0.1307	16,033	12,470	96	86
M14 x 2	0.178	21,872	17,011	151	136
M16 x 2	0.243	29,860	23,224	229	206
M18 x 2.5	0.298	36,516	28,401	317	285
M20 x 2.5	0.380	46,596	36,241	457	412
M22 x 2.5	0.470	57,627	44,821	612	551
M24 x 3	0.547	67,136	52,217	782	704
M27 x 3	0.711	87,296	67,897	1,143	1,029
M30 x 3.5	0.870	106,696	82,986	1,549	1,394
M33 x 3.5	1.076	131,991	102,659		
M36 x 4	1.266	155,384	120,854		
M39 x 4	1.513	185,624	144,374		
M42 x 4.5	1.74	213,011	165,675		
M45 x 4.5	2.02	247,245	192,302		
M48 x 5	2.28	279,577	217,449		
M52 x 5	2.73	334,732	260,347		
M56 x 5.5	3.15	386,082	300,286		
M60 x 5.5	3.66	448,845	349,101		

## Additional Bolting Information

When high radial loads exist, catalog curves may not suffice in checking the adequacy of the bolted joint. In such cases, the clamping friction contact bond must also be checked. If the clamping friction contact bond is insufficient to transmit the radial load, additional fasteners or other restraints must be provided.  Contact Rotek for assistance in such cases.

To avoid the loss of preload through creep, the maximum surface compression in the contact surfaces of the bolt head and the nut/material of the preloaded parts should not exceed yield. The approximate determination of surface pressure, P, underneath the bolt head or nut contact area is given by the following equation:

$$P = \frac{F_M}{0.9 \cdot A_P} < S_y$$

$A_P$  = Contact Area

$$A_P = \frac{\pi}{4} (d_w^2 - d_h^2)$$

$d_w$  = OD of bolt head contact area or washer diameter (if washer is used)

$d_h$  = Hole chamfer diameter (or hole diameter if no chamfer)

$F_M$  = Clamp Load (page 22)

$S_y$  = Limiting material yield strength

Adequate thread engagement is required to avoid stripping threads in tapped holes. Table 3 lists minimum thread engagement lengths for various material strengths.

Thread pitch errors (which may occur especially when thread engagement is  $> 1 \cdot D$ ) could lead to false tightening torque readings and a lower bolt preload force. Thread pitch errors must be minimized.

Bolts that are too long for blind tapped holes may bottom out in the holes before full bolt preload is reached. This could lead to false tightening torque readings. Under these circumstances the capacity of the slewing ring is compromised and low-cycle fatigue of the bolts will occur.

Table 4 provides a reference for bolt yield strengths.

**Table 3:**

Minimum thread engagement in tapped holes (coarse threads)				
Metric Bolt Class (DIN/ISO)	10.9		12.9	
	A-490/Grade 8		A-574	
Inch Bolt Class (ASTM/SAE)				
Bolt Diameter, D (inches)	<1.25	$\geq 1.25$	<1.25	$\geq 1.25$
Threaded material yield strength				
up to 35 ksi	1.25·D	N/A	N/A	N/A
35 to 50 ksi	1.0·D	1.2·D	1.2·D	1.4·D
50 to 100 ksi	0.9·D	1.0·D	1.0·D	1.1·D

**Table 4:**

Minimum yield strength according to bolt classification	
Bolt Class	Minimum Yield
ASTM A-490/SAE Grade 8	130 ksi [896 MPa]
DIN/ISO 10.9	136 ksi [940 MPa]
ASTM A-574 (D $\leq 0.5$ inch)	(150 ksi [1034 MPa])*
ASTM A-574 (D $> 0.5$ inch)	(145 ksi [1000 MPa])*
DIN/ISO 12.9	160 ksi [1100 MPa]

\* ASTM A-574 does not specifically state yield stress. These values approximate.

Note: High-strength bolts having other yield strengths may be uniquely marked and classified by a specification unique to the bolt manufacturer. Consult the bolt manufacturer for certification and purchase only from trusted sources.



### Turning Torque Calculations

Turning torque can be substantial and must be taken into consideration when dealing with large diameter slewing rings. Classical theory and empirical data has been used in establishing a means to estimate slewing ring turning torque. Using the equations and values on this page, a design torque value can be derived.

Factors affecting torque include the slewing ring's frictional coefficient, the applied loads, the load distribution, the mounting orientation, the rolling element separators, the flatness and stiffness of the supporting structure, the viscosity and amount of grease in the slewing ring, the seal type and preload, and the presence of lubrication at the sealing interface. In addition there are other forces such as gravity, wind and inertia that must be overcome to rotate a slewing ring. The torque required to rotate a slewing ring is a function of all of these influences.

#### 1. Freestate Torque, $T_F$ :

Freestate torque,  $T_F$ , is the frictional torque of the slewing ring as it arrives "out of the box" before any other load is applied. Freestate torque is usually ignored when slewing ring loads are high. However, under relatively light loads, freestate torque values must be taken into account. An estimate of turning torque for most slewing rings may be taken from the following graph:

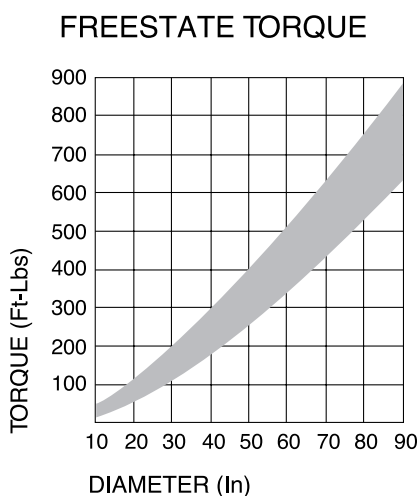

This graph results from a statistical study of Series 3000 type ball slewing rings with diameters from 12 inches to 90 inches, two seals, ground raceways, and internal clearance. These curves do not include peak values.

Slewing rings without seals typically exhibit lower freestate torque. Preloaded slewing rings (slewing rings manufactured with negative internal clearance) typically exhibit greater freestate torque. Freestate torque for special slewing ring designs must be evaluated on an individual basis.

☞ If required, specially designed slewing rings with reduced torque can be supplied. Contact Rotek for more information.

#### 2. Load Friction Torque, $T_L$ :

The load friction torque is due to the magnitude of the slewing ring loads. Average running torque,  $T_R$ , under ideal conditions can be found according to the following equation:

$$T_R = \frac{\mu}{2} \left( k \cdot M_K + \frac{F_A \cdot D_L}{12} + \frac{k \cdot F_R \cdot D_L}{24} \right)$$

Starting torque,  $T_S$ , is typically one-third greater than the running torque:

$$T_S \approx 1.33 \cdot T_R$$

Turning torque can vary considerably even between supposedly identical slewing rings. To account for peak loads, it is recommended that a significant service factor be employed to assure that sufficient power will be available to rotate the slewing ring even under adverse circumstances. The suggested design load friction torque,  $T_L$ , is calculated as follows:

$$T_L = f_T \cdot T_R$$

where  $f_T$  is a value from 2 to 5.

The highest value of  $f_T$  should be used when the supporting surfaces are at the high end of the flatness and stiffness limits (see page 30) and for designs that will be operated until the maximum wear allowable wear limit is reached (see page 32).

#### 3. Other Torque Loads, $T_E$ :

In addition to frictional torque, other sources of torque must be considered when sizing a drive unit. These may include effects from wind loads, gravitational forces, drag loads, and acceleration inertia.

$$T_E = T_{\text{wind}} + T_{\text{gravity}} + T_{\text{drag}} + T_{\text{inertia}} + \dots$$

#### 4. Slewing Ring Torque, $T$ :

Slewing ring torque,  $T$ , is the summation of freestate, load friction and all other external torque load components.

$$T = T_F + T_L + T_E$$

Power Requirements,  $P$ :

$$P = \frac{n \cdot T}{5252 \cdot \eta} [\text{hp}]$$

1 hp = 745.7 watts

Symbols Used [units]:

$D_L$  = Slewing ring race diameter [inches]

$F_A$  = Axial load [lbs.]

$F_R$  = Radial load [lbs.]

$k$  = Load distribution factor.  $k = 4.37$  for ball slewing rings and  $k = 4.1$  for roller slewing rings.

$M_K$  = Moment load [ft-lbs.]

$n$  = Rotational speed [rpm]

$P$  = Power [horsepower, hp]

$T$  = Turning torque [ft-lbs.]

$\eta$  = Drive efficiency

$\mu$  = Friction coefficient

Friction Coefficient,  $\mu$ , values for various slewing ring models:

= 0.008 for Series 2100: L4, L6

= 0.006 for Series 2100: L9

= 0.006 for Series 3000

= 0.004 for Series 4000

= 0.004 for Series 5000

= 0.004 for Series 6000

= 0.004 for Series 7100

= 0.004 for Series 8000

= 0.003 for Series 10,000

## Gear Capacity

Many Rotek slewing rings are supplied with gear teeth cut in one of the race rings. Adequate gear capacity must be verified.

The catalog listings provide tangential tooth load capacities. The catalog value is the rated static stall capacity for the tooth.

Intermittent shock loads should not exceed 140% of the catalog rating.

To achieve a reasonable gear life, it is recommended that the normal maximum working load not exceed 71% of the catalog ratings. This is a general guideline that is suitable for a wide range of Rotek applications, however, may not be suitable for all applications.

In high use or continually revolving applications, special dynamic calculations may be in order. Such applications require additional, separate calculations. ☎ Contact Rotek for assistance.

Tangential tooth load is related to turning torque according to the following equation:

$$TTL = \frac{24 \cdot T}{PD}, \text{ where}$$

TTL = Tangential tooth load (lbs.)

T = Turning Torque (ft-lbs.)

PD = Gear Pitch Diameter (inches)

The number of teeth, N, the diametral pitch, DP, and the pitch diameter are related as follows:

$$PD = \frac{N}{DP}$$

The above equations are valid for either the ring gear or pinion.

The tangential tooth load of the pinion always equals the tangential tooth load of the gear:

$$TTL_{pinion} = TTL_{gear}$$

## Verifying Gear Capacity of a Specific Slewing Ring Design

Example: The pedestal lift using model A10-35N1L always operates indoors and on a level surface. The internal ring gear will be driven by a single, 18 tooth pinion. The slewing ring is accelerated and decelerated very slowly to and from rest resulting in minimal inertia forces. A stop prevents full rotation of the slewing ring. At the stop, the pinion drive stalls with 30000 inch-pounds of torque.

### Nominal Maximum Working Loads:

1. Starting torque is estimated with the formulas defined on page 24 of the catalog:

$$T = T_F + T_L = T_F + f_T \cdot \frac{\mu}{2} \left[ \frac{F_A \cdot D_L}{k \cdot M \cdot K} + \frac{k \cdot F_R \cdot D_L}{12} + \frac{\quad}{24} \right]$$

$$T = 250 + 2 \cdot \frac{.006}{2} [(4.37)(276000) + \frac{(61000)(35)}{12} + \frac{(4.37)(0)(35)}{24}]$$

$$T = 8554 \text{ ft-lbs}$$

2. The tangential tooth load under normal maximum working loads is calculated using the gear pitch diameter, PD, shown in the catalog listing. PD = 31.429 inches from the catalog listing.

$$TTL = \frac{24 \cdot T}{PD} = \frac{(24)(8554)}{31.429} = 6532 \text{ lbs}$$

3. From the catalog listing for slewing ring model A10-35N1L, the tangential tooth load capacity is 12100 lbs. The normal working capacity is 71% of this value.

$$\text{Normal working load capacity} = (.71)(12100) = 8591 \text{ lbs}$$

$$6532 \text{ lbs working load} < 8591 \text{ lbs normal working load capacity}$$

✓ Okay for normal loads

### Gear Stall Loads:

1. The pitch diameter, PD<sub>pinion</sub>, of the pinion is calculated based on the diametral pitch, DP, and the number of pinion teeth, N<sub>pinion</sub>.

$$PD_{pinion} = \frac{N_{pinion}}{DP} = \frac{18}{3.5} = 5.1429"$$

2. Pinion torque, T<sub>pinion</sub>, at stall, = 30000 in-lbs = 2500 ft-lbs

3. The pinion tangential tooth load, TTL<sub>pinion</sub>, is determined as:

$$TTL_{pinion} = \frac{(24)(T_{pinion})}{(DP_{pinion})} = \frac{(24)(2500)}{(5.1249)} = 11667 \text{ lbs}$$

4. TTL<sub>gear</sub> = TTL<sub>pinion</sub> = 11667 lbs

5. 11667 lbs (stall load) < 12100 lbs (stall capacity)

✓ Okay for stall loads

### Dynamic Gear Loads:

In continually revolving or high use applications, dynamic capacity, rather than static capacity, may govern the gearing requirement. Such applications require additional, separate calculations. ☎ Contact Rotek for details.

Induction Hardening Note: Certain models have gear teeth induction hardened for wear resistance. Induction hardened gearing can provide a substantial improvement in gear life against surface wear and fatigue.

### Gearing

Rotek large-diameter slewing rings are, in the majority of cases, supplied with spur gearing. A gear cut into one of the slewing rings offers the advantage that an additional driving gear is not required, which helps to reduce design work and costs.

All slewing rings depicted with gears are, of course, available ungeared.

Special gear types, including those for slewing rings with diameters exceeding those shown in Rotek product catalogs, are also available upon request.

The permissible tangential forces are listed in the dimensional tables of respective Rotek products. The maximum values shown in these tables refer to stall load conditions.

The permissible bending stresses at the root of the tooth for 250/300 BHN quenched and tempered material is:

- 25,000 psi for normal loads
- 35,000 psi for stall loads and
- 50,000 psi for shock loads

⚠ Higher values may be allowed for infrequently occurring extreme loads, but these applications should be reviewed and approved by Rotek.

(See operating conditions and special requirements, page 36.)

For the bending stress calculation it should, however, be noted that the meshing conditions in highly stressed gears are not comparable with those of standard gear transmissions where slewing ring mounting and shafts can be regarded as relatively rigid.

In large-diameter slewing rings, the drive is generally mounted overhung. Due to the high tangential forces to be transmitted, the pinion shaft will bend. It is, therefore, not advisable to employ a contact ratio for preliminary design purposes.

In the case of highly stressed gears, a tip relief may be desirable (see page 28).

The slewing rings listed in the catalog tables are sometimes provided with an addendum or profile modification. Rotek should be provided the pinion data in order to check the meshing conditions. During the installation of the large-diameter slewing ring and the drive pinion, adequate backlash must be assured.

Three teeth can be marked in green at the highest point of eccentricity. This will allow satisfactory adjustment of the backlash.

After final assembly of the equipment and after tightening all of the fastening bolts, the backlash must be checked using a feeler gauge or a lead wire.

The minimum allowable backlash is dependent upon the precision of the slewing ring, the rigidity of the mounting structure, and the pitch of the gear teeth.

⚠ Most models have gear teeth that are cut with sufficient backlash to allow for proper meshing on standard center distances. Call Rotek for more information.

For gears subjected to high tooth flank stress, hardened gears have proven very satisfactory. Depending on pitch diameter and ring diameter, the gear rings are subjected to spin hardening or individual tooth induction-hardening, with the latter predominantly in the form of tooth contour hardening. Both methods provide improved flank load carrying capacity. Flank hardening with hardness phase-out in the region of the root radii, leaving the root radius unhardened, will reduce the load capacity at the root.

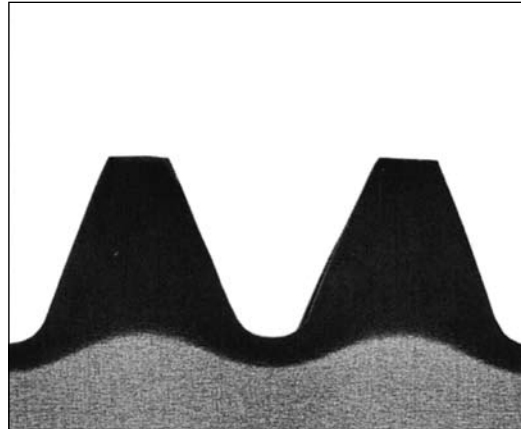

Figure 14: Spin hardening

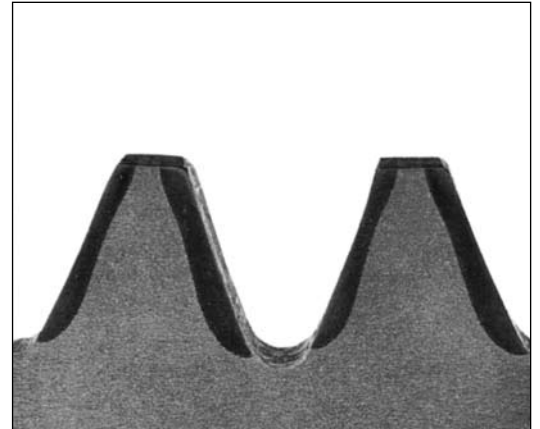

Figure 15: Tooth flank hardening

Hardened gears require an individual calculation. Pinion/gear alignment is more critical with surface hardened gearing. If misalignment or deflection is excessive, tooth breakage may occur prematurely, making it even more critical than tooth flank wear.

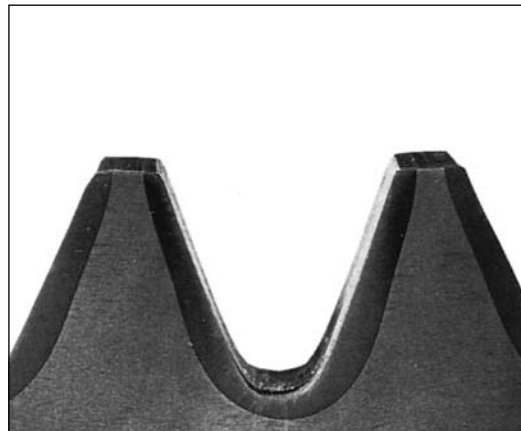

Figure 16: Tooth contour hardening

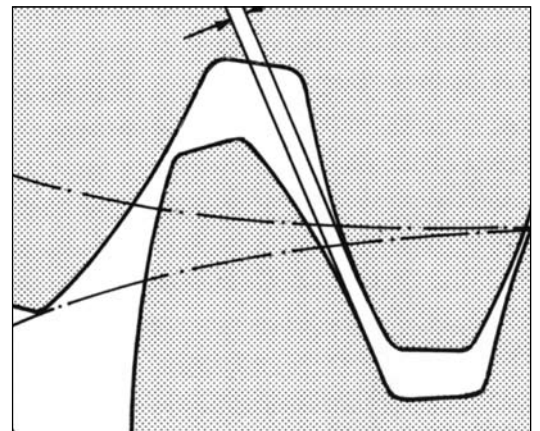

Figure 17: Backlash

Catalog models with induction hardened gears are hardened according to Figure 16 (tooth contour hardening).

### Pinion Tip Relief

Despite geometrically correct profiles and theoretically adequate gears, meshing problems may still occur in highly stressed gears, e.g. “scuffing” or “chipping” at the dedendum flank of the wheel, as shown in Fig. 18.

Figure 18

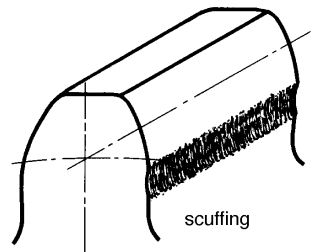

This phenomenon occurs primarily in gears with hardened pinions where the tip edges of the pinion act as scrapers.

Various causes may be responsible.

#### 1) Bending

Dynamic load peaks under high force applications, accelerations, braking actions or vibrations will cause elastic deformations in the meshing teeth.

#### 2) Pitch errors

Manufacturing tolerances in gears cannot be prevented, especially pitch errors, which in combination with the bending effect can produce negative influences.

#### 3) Drive unit

Most slewing drive units are mounted in an overhung arrangement, and deflections of the pinion shaft are unavoidable. The high forces will simultaneously produce elastic deformations at the interface of the slewing drive and mounting structure. Such deformations may also lead to meshing problems.

#### 4) Lubrication

The three influential factors mentioned will result in high peak loads acting on the tip edge of the pinion, which can cause the lubricant film to break.

The direct metallic contact will worsen the chipping effect.

Occasional damage which has occurred in the past, can now be prevented by providing a tip relief at the pinion and a radius at the tip edge of the pinion.

Tip relief has become a means of reducing the effects of vibration (noises) in high-speed gear mechanisms.

Investigations have led Rotek to specify pinion tip relief for applications with extreme load conditions, according to Figure 19.

The radius must blend into the addendum flank without forming an edge.

Figure 19

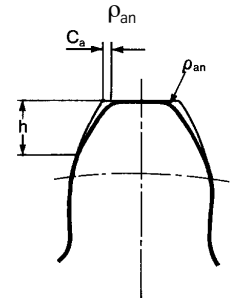

Where:

$$C_a = .01/D_p \text{ (inches)}$$

$$C_a = .01 \cdot m \text{ (millimeters)}$$

$$h = .4/D_p \text{ to } .6/D_p \text{ (inches)}$$

$$h = .4 \cdot m \text{ to } .6 \cdot m \text{ (millimeters)}$$

$$h/C_a = 40 \text{ to } 60$$

(based on full depth tooth height)

$$\rho_{an} = .1/D_p \text{ to } .15/D_p \text{ (inches)}$$

$$\rho_{an} = .1 \cdot m \text{ to } .15 \cdot m \text{ (millimeters)}$$

$$D_p = \text{Diametral Pitch}$$

$$m = \text{module}$$

$$D_p = 25.4/m$$

## Companion Structures

Due to their specific load carrying capacity, Rotek slewing rings can transmit very high loads even at relatively small diameters. The bolts provided for mounting the slewing ring to its companion structure must be rated accordingly.

For reasons of economy, the cross sections of the slewing rings are kept relatively low in relation to their diameters. Therefore, the slewing rings depend on a rigid and distortion resistant structure which to a large extent will prevent deformations in the slewing rings under the operating loads, provided a positive bolt connection is used.

Figure 21 illustrates that the vertical support in the companion structures must be in the vicinity of the track diameter. This is in order to keep any deflection of the support surfaces under maximum operating load within the permissible limits.

Rotek offers seamless rolled rings for support structures in a multitude of cross sections and profiles, unmachined or machined to customers' draw-

ings which, for instance for flange ring supports (e.g. angular mounting ring, Figure 20), provide decisive advantages:

- Distortion-resistant fastening of the large-diameter slewing ring,
- Optimum load transfer between anti friction slewing ring and companion structure.

The contact surfaces for the slewing ring must always be flat to prevent the slewing ring from becoming distorted when it is bolted down. Careful machining of the contact surfaces is, therefore, absolutely essential.

☛ In some cases, if machining of the contact surfaces is not possible, irregularities in the surfaces can be compensated for by applying a curable plastic grouting of a high compressive strength. Rotek must be advised of the intent to utilize grouting, and must approve of its use for the specific application prior to installation.



Figure 20



Figure 21

**Table 5**

Track	Out-of Flatness including slope per support surface in inches		
	Double-row	Single-row	Roller
Diameter in inches $D_L$	ball slewing rings Axial ball slewing rings	ball slewing rings 4-point contact slewing rings*	slewing rings
to 40	0.008	0.006	0.004
to 60	0.010	0.007	0.005
to 80	0.012	0.009	0.006
to 100	0.014	0.010	0.007
to 160	0.016	0.012	0.008
to 240	0.020	0.016	0.012
to 310	0.024	0.020	0.016

The figures in Table 5 may not be used for special configurations of precision slewing rings which have a higher running accuracy and a small slewing ring clearance. \*Values may be doubled for standard Series 2100 models L4 and L6. For Series 1000 mounting flatness requirements, see page 40.

**Table 6**

Maximum permissible axial deflections for contact surfaces at a maximum operating load.	
Track-diameter in inches $D_L$	Maximum axial deflections in inches
to 40	0.024
to 60	0.031
to 80	0.040
to 100	0.051
to 120	0.063
to 140	0.080
to 160	0.100
to 180	0.118
to 200	0.142
to 220	0.165
to 240	0.189
to 280	0.228
to 310	0.275

### Permissible Out-of-Flatness and Deflection in Companion Structures.

The maximum permissible out-of-flatness, including slope and axial deflections are detailed in the respective tables.

The permissible deviations listed in Table 5 for the different design types are indicative values.

Should the values be exceeded, Rotek must be consulted.

Regarding the slope of the machined surfaces, the figures shown in Table 5 refer to a support width of 4 inches.

Another important factor is to ensure that the maximum value is reached only once per 180° sector.

To avoid larger deviations and the occurrence of peaks in smaller sectors, any deviations in the range of 0° - 90° - 180° must only rise or fall gradually.

As in the case of out-of-flatness, any deflections in the supporting structure must not be allowed to lead to localized buckling which might cause tight spots in the raceways. This could easily lead to local overloads. For this reason, the same conditions as for the out-of-flatness apply.

For the maximum permissible deflections given in Table 6, the permissible slope may be twice the value given in Table 5. (Reference width 4 inches).

The maximum permissible axial deflections shown in Table 6 apply to all slewing ring types and are indicated as a function of the track diameter of the slewing ring.

## Radial Slewing Ring Deflections

In addition to considering the permissible initial out-of-flatness and maximum deflections of the slewing ring support structure under load, it is also essential that radial deflections of the slewing ring structure are observed and controlled.

Due to the influence of a wide variety of parameters, it is not possible to publish actual permissible limit values for radial deflection for every style of slewing ring and application. In general, however, to assure uniform load distribution around the slewing ring, the relative radial displacement of the inner and outer slewing ring rings should not exceed the radial clearance built into the slewing ring. If higher relative deflections are suspected, more exact studies, such as finite element analysis, should be employed so that these deflections may be more accurately predicted and controlled.



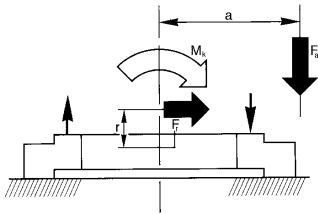

Figure 22: Loading principle for tilting clearance measurement.

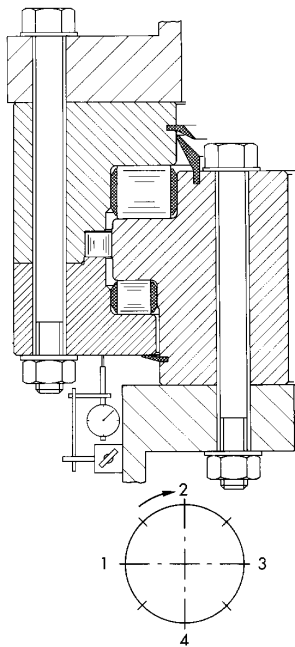

Figure 23: Three-row roller slewing ring slewing ring - basic test setup for tilting clearance measurement.

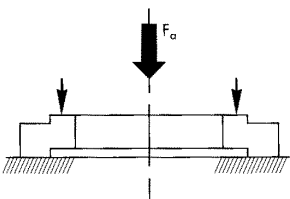

Figure 24: Loading principle for depression measurement.

### Wear Measurement

For assessing the condition of a slewing ring, we recommend that its normal wear rate be determined. The wear present in the raceway system shows itself by a change in the axial motion of the slewing ring. Depending on the individual conditions, wear can be determined either by measuring the tilting clearance or by depression measurements.

### Tilting Clearance Measurement

For equipment allowing both positive and negative application of moment loads, the respective loading principle is shown in Fig. 22.

The first measurement should be performed when the equipment is put into operation in order to obtain a base value for subsequent repeat measurements.

The measuring points should be marked around the circumference while the boom is kept in a specified position.

The measurements are then taken between the lower mating structure and the slewing ring bolted to the superstructure (Fig. 23).

The measurements should be taken as close to the slewing ring as possible in order to minimize the effect of elastic deformations in the system.

The dial gauges should have an accuracy of 0.0005 inches. Start with applying the maximum backward moment and set the dial gauges to zero. Then apply a forward turning moment, with load uptake, if necessary.

Slew the superstructure to the next position and repeat the measurement procedure.

When all positions have been measured, record the base values obtained in tabular form (Fig. 25).

The measurements should be repeated every twelve months as a minimum and under identical conditions as the base measurement.

The difference between the values measured and the base values represents the wear that has occurred.

If the wear is found to have greatly increased, the time intervals between measurements should be shortened.

☛ If the acceptable wear values (Tables 7,8 and 9 on page 33) are exceeded, please consult Rotek.

### Depression Measurement

In cases where the combination of both positive and negative loads are not possible, the following procedure should be applied. The loading principle is shown in Figure 24.

The first measurement should be performed when the equipment is put into operation in order to obtain a base value for subsequent repeat measurements.

Mark the respective measuring positions on the circumference while keeping the boom in a specified position.

The measurement is performed between the lower mating structure and the slewing ring ring bolted to the superstructure (Fig. 26).

Set the boom and load at a predetermined position to ensure a positive reading at each location. Excessive moment loads must be avoided to reduce elastic deformation.

Record the base values obtained in tabular form and allocate them to the respective base measurements (Fig. 27).

The depression measurement should be repeated every twelve months as a minimum, under identical conditions.

In case of heavy wear, the time intervals between measurements should be shortened.

Measurement		Base measurement	Test measurement	Test measurement
Measuring point 1 below	boom			
	counterweight			

Figure 25: Example of value recording for tilting clearance measurement

## Maximum permissible slewing ring clearances

**Table 7: Double-Row Ball Slewing Rings Series 4000**

Track diameter up to inches	Ball Diameter (inch/mm)										
	.625/16	.750/20	.875/22	1.000/25	1.25/30	1.375/35	1.50/40	1.75/45	2.00/50	2.25/60	2.75/70
	permissible increase in bearing clearance (inches)										
39	.071	.071	.075	.075	.079	.083	.098	.110			
49	.075	.075	.079	.079	.083	.087	.102	.114	.134	.142	
59		.079	.083	.083	.087	.091	.106	.118	.138	.146	
68			.087		.091	.094	.110	.122	.142	.145	.157
78				.091	.094	.098	.114	.126	.146	.154	.161
88					.098	.102	.118	.130	.150	.157	.165
98						.106	.122	.134	.154	.161	.169
108						.110	.126	.138	.157	.165	.173
118							.130	.142	.161	.169	.177
127							.134	.146	.165	.173	.181
137							.138	.150	.169	.177	.185
147							.142	.154	.173	.181	.189
157								.157	.177	.185	.197
177								.165	.185	.193	.205
196									.193	.201	.213
216									.201	.209	.217
236									.209		.224
255										.224	.232
275										.232	.240
295											.248
314											.256

If the deviation from the base measurement exceeds the maximum values shown in Tables 7, 8 and 9, please consult Rotek.

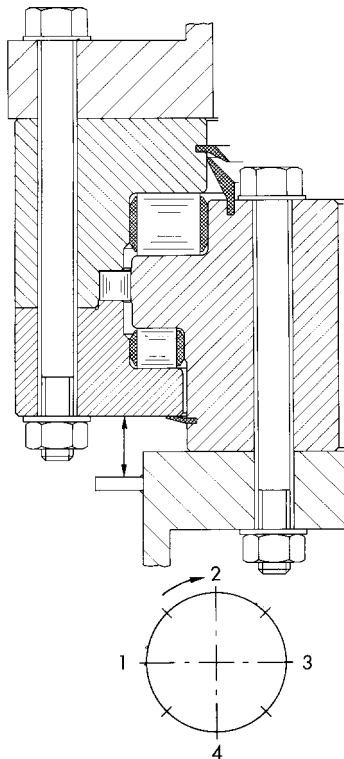

Figure 26: Three row roller slewing ring ring-basic test setup for depression measurement.

Measurement	Base Measurement	Test Measurement
Measuring point 1		
Measuring point 2		
Measuring point 3		
Measuring point 4		
Tester		
Signature		
Date		

Figure 27: Value recording in depression measurement.

**Table 8: Single-Row Ball Slewing Rings (4-Point Bearings) Series 2100 and Series 3000**

Track diameter up to inches	Ball Diameter (inch/mm)										
	.750/20	.875/22	1.000/25	1.25/30	1.375/35	1.50/40	1.75/45	2.00/50	2.25/60	2.75/70	
	permissible increase in bearing clearance (inches)										
39		.054	.054	.054	.058	.065	.073	.081	.096		
49			.058	.058	.061	.065	.077	.084	.100	.104	
59				.061	.065	.065	.077	.088	.100	.107	
68					.065	.069	.081	.088	.104	.111	.115
78					.069	.073	.084	.092	.107	.111	.119
88						.077	.088	.096	.111	.115	.123
98						.077	.088	.100	.111	.119	.123
108							.092	.100	.115	.123	.127
118							.096	.104	.119	.123	.130
127							.100	.107	.123	.127	.134
137								.112	.123	.130	.134
147								.115	.127	.134	.138
157									.127	.138	.142
177									.134	.146	.150
196									.142	.153	.157
216									.150	.161	.165
236									.157	.173	.177
255										.177	.180
275										.184	.188
295											.196
314											.203

**Table 9: Roller Slewing Rings Series 5000 and Series 10,000**

Track diameter up to inches	Roller Diameter (inch/mm)						
	.625/16	.750/20	1.00/25	1.25/32	1.50/40	2.00/50	2.25/60
	permissible increase in bearing clearance (inches)						
15	.008	.009	.009				
19	.008	.009	.009	.011			
24	.010	.011	.011	.013	.015		
31	.010	.011	.011	.013	.015		
39	.012	.013	.013	.015	.017		
49	.016	.017	.017	.019	.021	.024	
59	.020	.020	.021	.023	.025	.028	
78		.024	.025	.027	.029	.031	.035
98			.029	.031	.033	.035	.039
124				.035	.037	.039	.043
157				.039	.041	.043	.047
196					.044	.047	.051
236					.048	.051	.055
275						.055	.059
314							.063

### Set-up Information

#### Transport and Storage

Large-diameter slewing rings, like any other machine part, require careful handling. They should always be transported and stored in the horizontal position; if they must be transported vertically, they will require internal cross bracing. Impact loads, particularly in a radial direction, must be avoided.

#### Condition upon delivery (unless instructed otherwise):

Running System: Lubricated with a coating of one of the quality greases specified

Gear: Non lubricated; treatment as for external surfaces

External Surfaces: Tectyl 502 C or equivalent. This material can be washed off with petroleum-based solvents. Care must be taken to prevent these solvents from entering the slewing ring.

#### Preservation

Approximately 6 months in roofed storage areas. Approximately 12 months in enclosed, temperature-controlled areas. Extended storage periods will require special preservation.

#### Installation

The slewing ring support surface must be absolutely flat. (See page 30.) The upper and lower ring must make perfect contact and this must be checked using a leveling instrument or a feeler gauge. The contact surfaces require machining. Welding beads, burrs, excessive paint residues and other irregularities must be removed. Non-machined contact surfaces can be provided with cast resin grouting, but only if use of

grout was considered and approved by Rotek at the design stage.

The protective coating should be removed from the upper and lower mounting surfaces of the slewing ring as well as from the gear. No solvent should be allowed to come into contact with the seals and raceways. Gears already greased should not be cleaned.

All grease nipples must be easily accessible. Where necessary, grease pipes should be provided to allow relubrication through all grease holes.

#### Hardness Gap

The unhardened zone between the beginning and end of the hardened region of the raceway is identified by a stamped letter "S" near the nameplate or filler plug at the inner or outer diameter of each slewing ring. On a geared ring, the hardness gap is marked on the axial surface. On a point loaded ring, the hardness gap "S" should be positioned outside the main area of load, where possible.

#### Gear

At the point of maximum deviation of the pitch circle, three teeth are usually marked in green. This allows the satisfactory adjustment of the backlash. The backlash at the narrowest point should be at least 0.03/DP. After the final tightening of the bolts of the slewing ring the backlash should be checked around the entire circumference.

It must be verified that all the bolt holes in the slewing ring line up with the holes in the companion structure! Otherwise, the slewing ring may become distorted.

### Fastening Bolts

The standard is ISO grade 10.9, ASTM 490, or SAE J429/Grade 8. Bolts must be carefully pre-loaded crosswise to specified values. (See table 2 on page 22 for bolt tightening torque levels.)

The surface pressure under the bolt head or nut must not exceed the permissible maximum value (see page 23). Use hardened washers, if necessary. The minimum bolt length must be assured.

The determination of the tightening torques will not only depend on the bolt grade, but also on the friction in the thread and the contact surface of the bolt head and nut. The tightening torques given in Table 2 on page 22 are recommended values based on lightly oiled threads and contact surfaces. Dry threads will require higher torques while heavily oiled threads will require lower tightening torques. The values may, therefore, vary considerably. This applies in particular to threads M 30 or 1-1/4", and larger. For bolts of this size and larger we recommend the use of hydraulic tensioning devices.

⚠ Welding of the slewing ring or welding in the vicinity of the slewing ring should not be permitted as the heat generated may cause distortions of the slewing ring. Exceptions to this rule will require prior written approval from Rotek.

## Lubrication and Maintenance

The first relubrication of the raceway and the lubrication of the gear should be carried out immediately after installation. For this and subsequent lubrication, the lubricants in Table 10, or their equivalent, are to be used. These raceway greases are lithium-saponified mineral oils of NLGI Grade 2 with EP additives. The raceway lubricants listed in Table 10 can be mixed together. The lubricants are listed in random order and not according to quality.

The grease filling is there to reduce friction, seal the slewing ring and to provide protection against corrosion. Therefore, the slewing ring must always be liberally greased so that a collar of fresh grease forms at the gaps and seals around the whole circumference of the slewing ring. Ideally, the slewing ring should be rotated during relubrication.

Figure 28

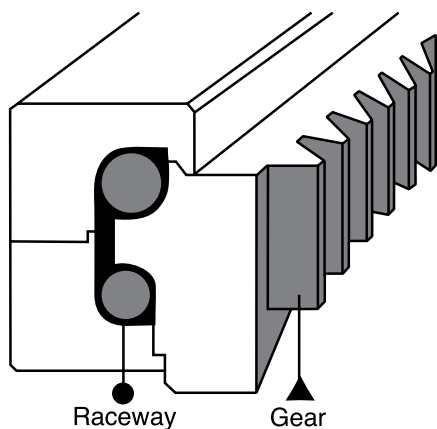

### Lubricants

Queries concerning lubricants should be answered by their respective manufacturer. The greases listed in Table 10 are approved for our large-diameter slewing rings and tested for compatibility with the materials utilized for spacers and seals.

**Table 10: Recommended Lubricants**

	Raceway	Gear
76 Lubricants	Unoba EP2	Gearite HDCF 4800
Castrol	Molub-Alloy 220 ES	Optimol Viscogen 0
Exxon	Ronex MP	Surret Fluid
Kluber	Centoplex 2 EP	Grafoscon C-SG 0 Plus
Mobil	Mobilux EP2	Mobiltac 375NC
Shell	Alvania EP2	Cardium Fluid M or H
Sunoco	Ultra Prestige 2 EP	
Texaco	Multifak EP2	Crater 2x Fluid or 5x Fluid

When employing other lubricants, the user must obtain confirmation from the lubricant manufacturer or supplier that the grease he has chosen is suitable for the intended application and that its properties are at least equivalent to those of the greases listed in Table 10, and ensure the lubricant is compatible with non-metallic components.

When automatic lubricating systems are used, the lubricant manufacturer must confirm pumpability. For applications at very low temperatures, special greases are required.

The gear lubricants specified are suitable for manual application in low-speed outdoor use.

### Lubrication Intervals

Lubrication intervals are to be selected according to the operating conditions; generally every 100 operating hours, for ball slewing rings and every 50 hours for roller slewing rings. Shorter lubrication intervals must be used in tropical regions, in the presence of high humidity, dust or dirt, significant fluctuations in temperature, and where there is continuous rotation.

For automatic lubrication systems, a quantity of one gram of grease per fitting per hour is recommended for general applications. The grease may be added hourly or at other scheduled intervals.

☛ Special instructions apply for bogie slewing rings for railroad vehicles.

Before and after prolonged stoppage of the equipment, relubrication is absolutely necessary. This is especially important after a winter shutdown. When cleaning the equipment, care must be taken to prevent cleaning agents from damaging the seals or penetrating into the raceways.

### Checking of Bolts

The bolt connection has to keep a sufficient preload during the entire slewing ring life. Re-fastening on a regular basis may be necessary for compensation of settling phenomena.

### Checking of the Raceway System

When delivered, large-diameter slewing rings have clearances which ensure good running properties and functional safety. After a prolonged period of time, clearances will increase. It is therefore necessary to check these clearances at certain intervals. (See page 32.)

### Operating Conditions and Special Requirements

The data contained in this catalog refers to slewing rings with applications involving oscillating motions or slewing movements.

It is, of course, possible to use large-diameter slewing rings for higher circumferential speed. For such requirements it is necessary to carry out special checks on the raceways and gears and to adapt these to the operating conditions if need be. Inquiries concerning such applications should include a description of the operating conditions as well as the customer's requirements.

☞ If the slewing ring is to be installed with its axis in the horizontal position, Rotek should be consulted prior to the selection of a slewing ring model.

### Operating temperature

Standard design slewing rings are suitable for operating temperatures ranging from 13° F (-25°C) to +140° F (+60°C). The various operating temperatures require suitable lubricants. (see information on page 35)

☞ For higher or lower operating temperatures and/or temperature differences between the outer and inner rings, Rotek must be advised beforehand so that checks can be carried out. Requirements regarding the mechanical properties of the ring material are of particular importance. In many cases, for instance, a minimum notch impact strength will be required for applications at sub zero temperatures.

### Classification/special conditions

Several applications, such as off-shore installations and ship deck cranes, require classification. For this purpose, the respective classification agencies have produced a catalog of requirements and specify acceptance of the slewing ring in accordance with that document.

In order to take such specifications into account when preparing our quotations, Rotek should be advised of any specifications requirements, in detail, prior to the selection of a slewing ring model.

### Seals

The seals provided in the slewing ring gaps prevent dust and small particles from directly entering the raceways and retain fresh lubricant in the slewing ring gaps. In this function, they have proven satisfactory under normal operating conditions for many years.

Adequate relubrication, i.e. until a uniform collar of grease appears around the circumference of the slewing ring, is required for this function to be assured.

As sealing materials are subject to aging when exposed to a number of environmental conditions, seals require maintenance and, depending on their condition, may have to be replaced.

Applications in a heavily dust-laden atmosphere, such as mechanical handling equipment for coal and ore, will require special seals.

Slewing rings in ship deck and floating cranes are often exposed to splash and surge water. In such cases we use a special seal as shown in Figure 29.

Figure 29

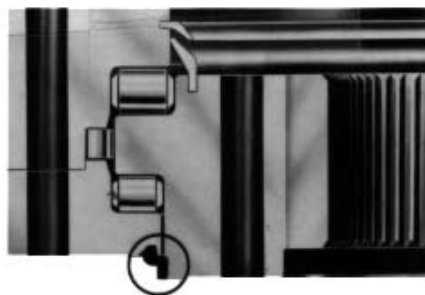

Installing this type of seal may increase the height of the slewing ring.

For these applications it is preferable to use slewing rings with internal gears where the gear is protected by the surrounding structure.

### Raceways

In most designs, plastic spacers are inserted between the rolling elements in the raceways. Penetration of aggressive materials into the raceways must be prevented on all accounts. Aggressive materials will alter the lubricating properties which will lead to corrosion in the raceways and damage the plastic spacers.

### Special designs

In addition to standard slewing ring series, Rotek can provide slewing rings tailored to specific operating conditions with regard to dimensions, running accuracies, slewing ring clearances and materials. We also manufacture wire-race slewing rings. This slewing ring permits the use of non-ferrous metal rings and thus meets any special requirements regarding minimum weight, resistance to corrosion, etc.

### Packing

Generally, large-diameter slewing rings will be wrapped in a protective material for transport. The external slewing ring surfaces are protected against corrosion by means of Tectyl 502 C (oily), or equivalent, and by filling the raceways with lithium-based grease.

The method of transport will determine the type of packing used (e.g. pallets, crates).

Standard packing will provide adequate protection for storage times of up to one year in enclosed, temperature controlled areas.

Upon request, other preservation and packing methods can be provided for longer storage times (e.g. long term packing for years' storage).

## Slewing Ring Design Worksheet Instructions

Slewing ring design assistance is available from Rotek without charge

Rotek's Application Engineering department is available, without charge, to assist design engineers in the design or selection of an appropriate large-diameter slewing ring for their specific application.

To facilitate this process, this catalog includes a Slewing Ring Design Worksheet on the two pages that follow. It provides a convenient method of summarizing the information required to engineer a slewing ring specific to your needs.

### How to use the Slewing Ring Design Worksheet

Here are the suggested procedures for the use of the Slewing Ring Design Worksheet:

1. Photocopy the Design Worksheet appearing on pages 38 and 39.
2. Complete the Design Worksheet, providing requested information for your application.

☎ Feel free to contact Rotek at 1-800-221-8043 with any questions you may have.

3. Include any drawings or load sketches that might assist in providing a detailed explanation of your application.

4. Send the completed Design Worksheet and any additional information to:

Rotek Incorporated  
1400 Chillicothe Road  
Aurora, OH 44202

or fax the form and information to:

Rotek Application Engineering at,  
330/562-2709.

# Engineering Section

## Rotek Slewing Ring Design Worksheet

Also available online at [www.Rotek-inc.com](http://www.Rotek-inc.com)

Company Name \_\_\_\_\_

Address \_\_\_\_\_

City \_\_\_\_\_ State \_\_\_\_\_ Zip \_\_\_\_\_

Telephone \_\_\_\_\_ Fax \_\_\_\_\_

Your Name \_\_\_\_\_ Title \_\_\_\_\_

Application description \_\_\_\_\_

\_\_\_\_\_

\_\_\_\_\_

\_\_\_\_ New Application

\_\_\_\_ Replacement slewing ring for \_\_\_\_\_

Project reference \_\_\_\_\_ Part reference \_\_\_\_\_

Machine Model \_\_\_\_\_

### Slewing Ring Loads/Speeds/Duty (required data)

Load condition	<u>1</u>	<u>2</u>	<u>3</u>
Axial load*	_____ lbs	_____ lbs	_____ lbs
Moment load	_____ ft-lbs	_____ ft-lbs	_____ ft-lbs
Radial load	_____ lbs	_____ lbs	_____ lbs
Gear tooth load**	_____ lbs	_____ lbs	_____ lbs
or gear torque**	_____ ft-lbs	_____ ft-lbs	_____ ft-lbs
Duty (% of rotation)	_____ %	_____ %	_____ %
Mean rotational speed	_____ rpm	_____ rpm	_____ rpm

\*Enter axial loads as a positive value if compression and as a negative value if tensile.

\*\*Tooth loads are loads per tooth. Torque load is total torque on the ring gear

Rotating race  Outer race  
 Inner race

Axis of rotation  Vertical axis (Mtg horizontal)  
 Horizontal axis (Mtg vertical)

Direction of rotation  Primarily unidirectional  
 Oscillating

Amount of rotation  Continuous  
 Intermittent

Maximum speed \_\_\_\_\_ rpm

Incline \_\_\_\_\_ ° from vertical axis

Max. angle of rotation \_\_\_\_\_ °

Required life \_\_\_\_\_

Space Limits

Preferred

Range

Outside diameter	_____ inches	_____ inches (max.)
Inside diameter	_____ inches	_____ inches (min.)
Overall height	_____ inches	_____ inches (max.)
Raceway diameter	_____ inches	_____ inches (min.) _____ inches (max.)

Gearing (include drawing of pinion if possible)

External gear       Internal gear       No gearing

Tooth form \_\_\_\_\_

Required reduction ratio \_\_\_\_\_

Number of pinion teeth \_\_\_\_\_

Number of pinion drives \_\_\_\_\_

Bolts

SAE only       Metric only       SAE or Metric

Outer race bolt holes       Thru  
 Thru and counterbored  
 Tapped  
 Tapped and counterbored  
 No preference

Inner race bolt holes       Thru  
 Thru and counterbored  
 Tapped  
 Tapped and counterbored  
 No preference

Special requirements (check where applicable)

- Manual rotation
- Seals required
- Extremely dirty
- High temperature (>125°F)      Max temperature \_\_\_\_\_ °F
- API,ABS,DNV or Lloyds certification required
- Precision/preloaded slewing ring (Please provide details below)
- Precision gearing. Gear quality \_\_\_\_\_
- Rolling elements must be caged. No spacers.
- No grease lubrication
- Oil lubrication
- Specific location of grease ports
- Outer race       OD  
 Mounting side  
 Non-mounting side
- Inner race       ID  
 Mounting side  
 Non-mounting side

Additional Comments \_\_\_\_\_





Rotek Series 1000 slewing rings comprise a line of inexpensive, versatile rolled-ring slewing rings made with unhardened, machined raceways. Designed for use as fifth wheels for trailers and farm wagons, Series 1000 slewing rings are available from stock in diameters from 12 to 42 inches. Thrust capacities range from 1650 to 35,200 pounds for fifth-wheel applications.

Assembled with a full complement of chrome-alloy steel balls without spacers, this series of Econo-Trak slewing rings has proved effective for many low-speed, bi-directional industrial applications where rotation is intermittent and loads are compressive. Series 1000 slewing rings may not be used in tension. Lift-off protection provided by the slewing ring design is only intended to keep the slewing ring together for handling and minor uplifts.

☎ If your application requires a slewing ring that can be tension loaded, contact Rotek.

Each Series 1000 slewing ring is a complete assembly in itself, requiring no additional components or accessories other than mounting fasteners. The slewing ring may be bolted directly to flat and rigid mounting structures.

The vertical, profiled web of the slewing ring must be supported to assure direct and uniform load transmission to the ball raceways.

At least 50 percent of the peripheral slewing ring flange mounting surfaces must be supported. Load slewing ring zones should be roughly equally spaced and (for fifth-wheel applications) oriented in the direction of travel and at right angles to travel. Total mounting surface out-of-flatness must not exceed .05 inches. The slewing rings in the turntables must be fastened with SAE grade 5 (or better) fasteners. The horizontal forces resulting from acceleration or deceleration must be transmitted by stops welded (or otherwise permanently fixed) to the mating structures so as to relieve the load on the bolts in the radial direction. The slewing ring must never be welded to the mating structure.

#### For Fifth-wheel Applications

Slewing rings may be applied up to the published thrust capacity limits. (See the dimensional tables on page 41.) Models with the prefix designation "M4" are normally used for low-speed applications such as farm trailers. They provide adequate radial capacity for deceleration rates up to 5 ft./sec<sup>2</sup>. The other models are recommended for normal highway service and provide adequate capacity for radial loading resulting from deceleration rates up to 11.5 ft./sec<sup>2</sup>.

To select a Series 1000 fifth-wheel slewing ring, merely determine the maximum weight which will be carried, and then select from the fifth-wheel capacity rating on page 41.

#### Other Applications

Series 1000 slewing rings have been successfully applied to certain tasks ordinarily thought appropriate only for Series 2100 slewing rings. If the application involves positioning-type, intermittent rotation and the center of gravity remains within the diameter of the slewing ring, a Series 1000 slewing ring may prove acceptable at a substantial savings in cost.

For applications where frictional torque is critical, such as turntables rotated manually, it is recommended that one or more prototype slewing rings be procured and

tested before committing them to a production design. If low-friction performance of the first unit is critical, another style of slewing ring may be more suitable. ☎ Call Rotek for assistance.

The recommended maximum raceway velocity for Series 1000 slewing rings is 100 feet per minute.

Published thrust capacity ratings should be derated by a factor of 2.7 for turntable applications that are manually rotated.

☎ If the center of gravity is off the center of rotation, contact Rotek engineering for assistance in sizing the slewing ring. Tension loaded applications are not permissible. (See page 14 for slewing ring load definitions.)

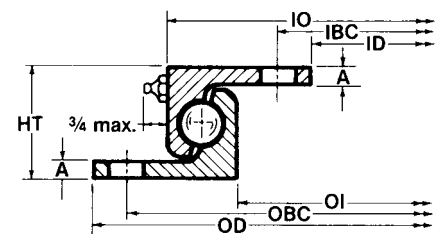

Fig. 1

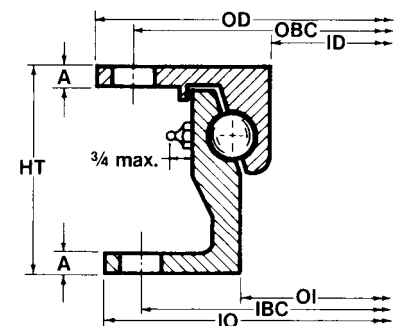

Fig. 2

☎ **Note:** All capacity curves and ratings assume that the slewing ring is mounted in compression. If slewing ring is mounted in tension, call us.

## Example 1

Cart is symmetrical – weight is equally distributed on front and rear axles. Slewing ring load is thus half of total, or 3250 lb.

Select slewing ring according to rated fifth-wheel capacity. Model M4-22P4 has capacity of 3300 lb., which exceeds required 3250 lb.

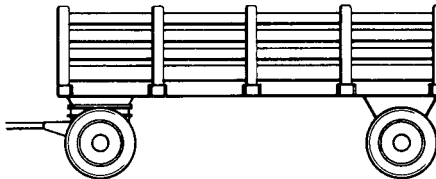

**Airport baggage cart**

Cart:	1500 lb.
Maximum Load:	<u>5000 lb.</u>
Total:	6500 lb.

## Example 2

Since axles are not symmetrically located, it is necessary to compute load on slewing ring. This may be easily done by summing moments about the centerline of the rear suspension as follows:

Weight of body and load x 11' = Force on front axle x 24'

$$F = \frac{52,000 \times 11'}{24'} = 23,800 \text{ lb.}$$

Appropriate slewing ring choice would be Model M6-39P1, which has capacity of 26,400 lb.

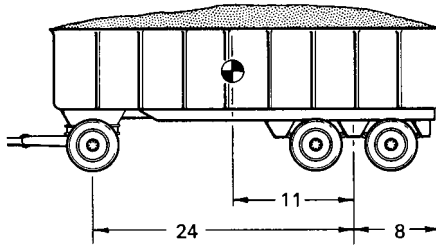

**Highway trailer**

Trailer Weight: (excluding suspensions and wheels)	14,000 lb.
Weight of Maximum Load:	<u>38,000 lb.</u>
Total Weight:	52,000 lb.

Model No. Less Mtg. Holes	Model No. With Mtg. Holes	Wt. (lbs)	Outline Dimensions (inches)							Mounting Holes* No of Capacity (lbs)			Holes Per Race	Thrust Fifth Wheel
			OD	ID	IO	OI	HT	A	OBC (in)	IBC (in)	DIA (in)			
M4-12P4	M4-12P4Z	24	15.9	9.3	13.6	11.6	1.65	.32	14.75	10.25	9/16	6	1,650	
M4-16P4	M4-16P4Z	33	19.8	13.2	17.6	15.5	1.65	.32	18.63	14.13	9/16	6	1,980	
M4-22P4	M4-22P4Z	44	25.7	19.1	23.5	21.4	1.65	.32	24.63	20.00	9/16	6	3,300	
M4-26P4	M4-26P4Z	51	29.7	23.1	27.4	25.4	1.65	.32	28.50	24.00	9/16	8	3,960	
M4-30P4	M4-30P4Z	60	33.6	27.0	31.3	29.3	1.65	.32	32.50	28.00	9/16	8	5,280	
M4-34P4	M4-34P4Z	66	37.6	30.9	35.3	33.2	1.65	.32	36.38	31.88	9/16	8	6,600	
M4-38P4	M4-38P4Z	75	41.5	34.9	39.2	37.2	1.65	.32	40.25	35.75	9/16	8	7,920	
M5-16P1	M5-16P1Z	40	19.6	12.4	17.1	15.0	1.9	.32	18.50	13.50	9/16	8	3,960	
M5-22P1	M5-22P1Z	50	25.6	18.3	23.0	20.9	1.9	.32	24.50	19.50	9/16	8	5,500	
M5-26P1	M5-26P1Z	60	29.5	22.2	26.9	24.8	1.9	.32	28.38	23.50	9/16	8	6,600	
M5-30P1	M5-30P1Z	70	33.5	26.2	30.9	28.8	1.9	.32	32.38	27.25	9/16	8	7,700	
M5-34P1	M5-34P1Z	75	37.4	30.1	34.8	32.7	1.9	.32	36.25	31.13	9/16	8	8,800	
M5-38P1	M5-38P1Z	85	41.3	34.1	38.7	36.7	1.9	.32	40.13	35.13	9/16	8	9,900	
Tolerances			+.313	+.125					±.012	±.012				
			-.200	-.313	±.125	±.080	±.125	±.063						
M5-31P1	M5-31P1Z	95	35.2	30.0	34.6	30.8	3.2	.35	34.00	33.50	9/16	8	15,400	
M5-36P1	M5-36P1Z	110	40.0	34.7	39.4	35.6	3.15	.35	38.75	38.25	9/16	8	18,000	
M5-40P1	M5-40P1Z	125	43.5	38.3	42.9	39.1	3.2	.35	42.38	41.75	9/16	8	19,800	
M6-35P1	M6-35P1Z	145	39.7	33.9	39.4	34.8	3.5	.39	38.38	38.00	9/16	8	22,000	
M6-39P1	M6-39P1Z	165	43.6	37.8	43.3	38.8	3.5	.39	42.25	41.75	11/16	8	26,400	
M7-39P1	M7-39P1Z	163	43.6	37.7	43.3	38.9	3.5	.39	42.25	41.75	11/16	12	30,800	
M7-42P1	M7-42P1Z	174	47.6	41.6	47.2	42.8	3.5	.39	46.25	45.75	11/16	12	35,200	
Tolerances			+.313		+.31				±.012	±.012				
			-.125	±.080	-.125	±.080	±.125	±.063						

\*Note: Standard Series 1000 slewing rings furnished without mounting holes. For slewing rings complete with mounting holes, add suffix "Z" to model number. Example: Model M4-12P4 complete with mounting holes becomes Model M4-12P4Z. There are 4 grease fittings, approximately equally spaced, that press-fit into a 1/4 inch diameter hole as shown. Rotek recommends consulting pages 12 - 36 for additional information that must be reviewed prior to slewing ring selection.

## Series 2100 Econo-Trak® Slewing Rings



This is the improved Econo-Trak® line of 4-point contact slewing rings with contact angles designed for optimum transfer of thrust and moment loads. Series 2100 slewing rings are available from stock in diameters from 13 to 57 inches. The mounting surfaces are machined, including the mounting holes. The slewing rings are supplied with chrome-alloy steel balls separated by spacers to prevent ball-to-ball scuffing.

Balls and spacers are plug loaded, and the filler plug and the adjacent raceway are relieved to prevent loading in this area. The filler plug or the hardness gap, marked "S" on the profile ring, must be located in the neutral, low load area.

It is imperative that these slewing rings be mounted on a distortion-proof mounting structure with uniformly stiff support for the entire circumference of the slewing ring rings. The contact surfaces must also be flat to avoid slewing ring distortion during bolting because this may cause tight spots in the raceways. The surfaces must be flat within the guidelines of pages 30 and 31. The slewing ring may be attached directly to a flat, rigid, mounting structure. If an unreinforced plate-type mounting structure is used, Rotek recommends the use of structural steel having a minimum yield strength of 50,000 pounds per square inch, and a minimum plate thickness, after machining, as follows:

L4 Models = 3/4 in.  
L6 Models = 1-1/4 in.  
L9 Models = 2 in.

For operating temperatures in the range of 0° F. to 176° F., see page 35, Table 10 for recommended raceway and gear lubricants. For temperatures outside the above range, please contact Rotek Engineering. 

This series of slewing rings is available with integral gears on either the inner or outer rings. The hardness of the gears is 180 - 225 BHN. The rating for the gears may be found in the Dimensional Tables on pages 46 and 47 in the column marked "Maximum Tangential Tooth Load."

The limiting load curves for raceways apply only to compressive axial loads, and they are indicated by a solid line on the load diagram. These diagrams are to be used with maximum loads including all additional loads such as test loads and impact loads.

Rotek has, through extensive research and testing, developed a bolt design specification which is based upon infinite bolt life, with proper maintenance and an approved load analysis. These limiting load curves for bolts, shown by dotted lines, on the limiting load curve diagrams, are based upon the following conditions:

- Use of ASTM A490 (grade 8) fasteners
- Prestress equal to 70% of yield strength
- Five joint interfaces in the connection
- Clamping length equal to 5 x fastener diameter
- Use of ASTM A563 (DH) nuts
- Use of ASTM F436 hardened washers

 In the case of a suspended axial (tension) load, the raceway and bolt calculations will have to be approved by Rotek Engineering.

Rotek has available from stock two standard models of the 2100 Series. These are identified by the suffixes "Z" and "ZD". Dimensionally these models are identical; they differ only in the number of bolt holes. Please see Dimensional Tables on pages 46-48.

The load rating diagrams for the "Z" and "ZD" models are clearly marked in the title block.

Rotek has standard pinions available for the Econo-Trak® slewing rings. Please see page 49 for details.

# Series 2100 Econo-Trak® Slewing Rings

## General Information

**Modifications:** Where quantity slewing ring purchases warrant the extra cost and production leadtime, Series 2100 slewing rings may be ordered with certain design modifications. These include special mounting hole spacing, special gear pitch or tooth form, etc.

**Note:** Piloted mounting is not recommended for Econo-Trak slewing rings, since ID and OD dimensions and concentricity are not closely held in relation to raceways.

Gear runout is held sufficiently close for satisfactory gear operation within speed limitations of 700 ft./min. Backlash variation is substantial, and requirements for tighter control of backlash should be referred to the factory.

**Grease fittings:**  
 L4 Models have (4) Drive fitting for 1/4 Drill.  
 L6 Models have (4) 1/4-28 NF (SAE-LT) fittings.  
 L9 Models have (6) 1/8-27 NPT fittings

**Min. Mounting Plate Thickness:**  
 (50,000 psi yeild strength)  
 L4 Models = 3/4 in.  
 L6 Models = 1-1/4 in.  
 L9 Models = 2 in.

Height Tolerance			
Model	L4	L6	L9
Gear face	—	±.04	±.04
Top of brg. to top of gear face	—	+ .02 - .05	±.04
Flange thickness	+ .02 - .04	+ .02 - .04	±.04
Overall height	+ .04 - .02	+ .02 - .05	±.04

**\*Series 2100 Mounting Hole Location Tolerances**

Bolt Circle Diameter	Location Tolerance
10.00 to 24.99	⊕ .030 diameter
25.00 to 39.99	⊕ .040 diameter
40.00 to 59.99	⊕ .050 diameter
60.00 up	⊕ .060 diameter

# Maximum Static Slewing Ring Capacity For Series 2100 Econo-Trak® Slewing Rings

**L6 Z MODELS**

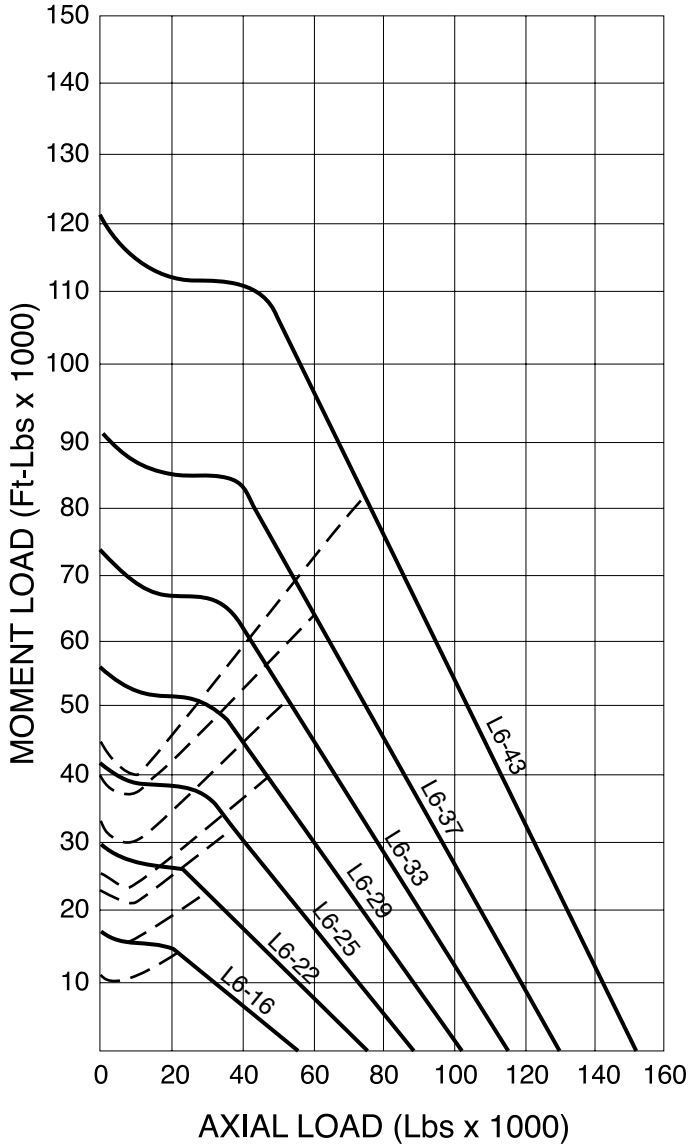

**L6 ZD MODELS**

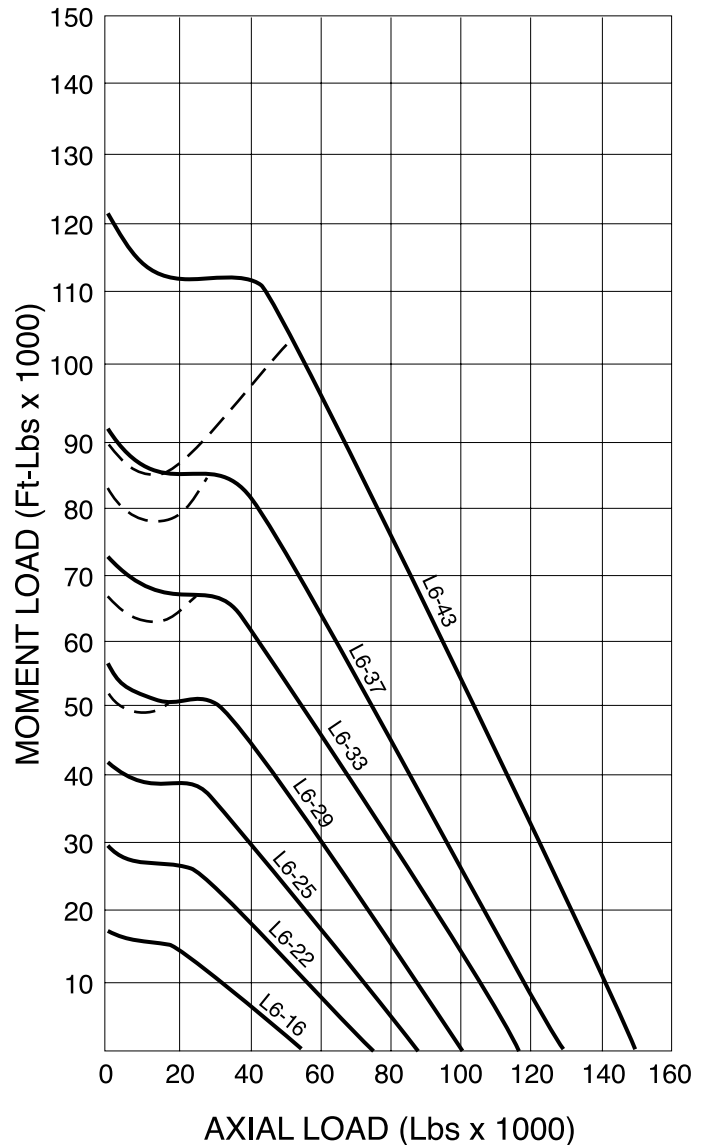

These load diagrams define both slewing ring raceway (i.e. solid line) and bolt (i.e. dotted line) limiting load rating curves for the Series 2100 Econo-Trak slewing rings.

Z and ZD model limiting load rating curves reflect differences in the number of mounting holes utilized. Higher capacities are achievable with modified bolt patterns, or by applying a "full" section interchangeable slewing ring. However, these modifications can only

be arranged with prior Rotek technical approval. Please call 800/221-8043 for technical assistance.

Pages 46 thru 48 dimensionally describe slewing ring cross sections for the above mentioned slewing rings.

# Maximum Static Slewing Ring Capacity For Series 2100 Econo-Trak® Slewing Rings

## L4 MODELS

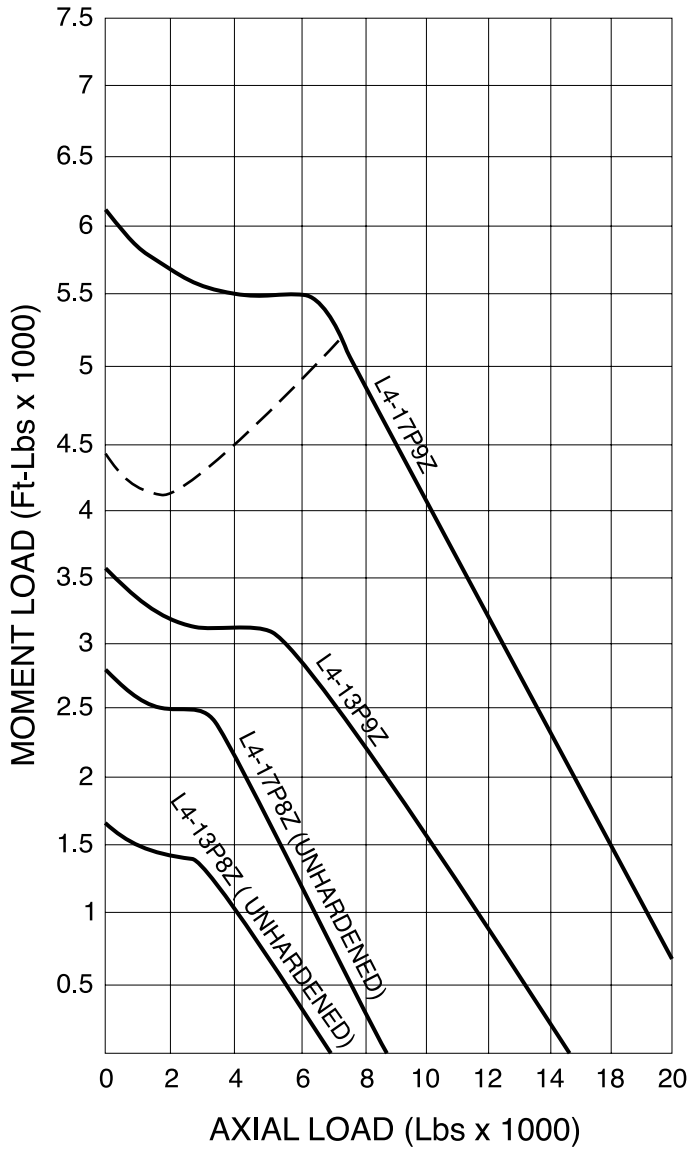

## L9 MODELS

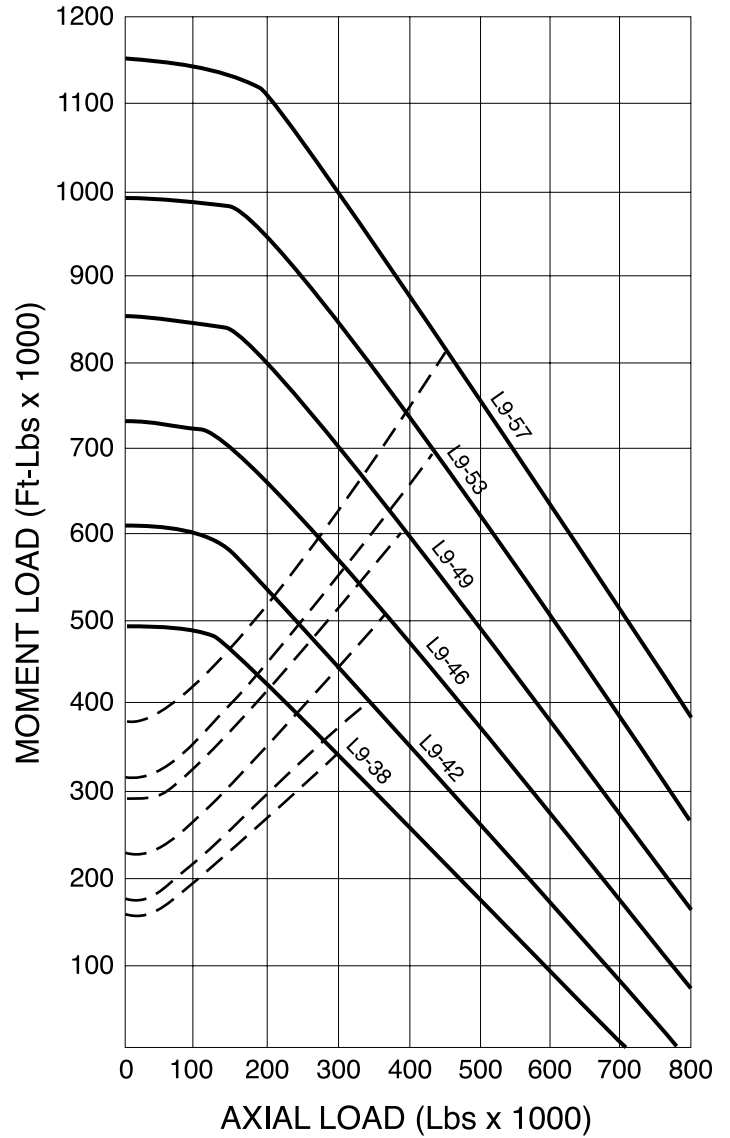

These load diagrams define both slewing ring raceway (i.e. solid line) and bolt (i.e. dotted line) limiting load rating curves for the Series 2100 Econo-Trak slewing rings.

Higher capacities are achievable with modified bolt patterns, or by applying a “full” section interchangeable slewing ring. However,

these modifications can only be arranged with prior Rotek technical approval. Please call 800/221-8043 for technical assistance.

Pages 46 thru 48 dimensionally describe slewing ring cross sections for the above mentioned slewing rings.

# Series 2100 Econo-Trak® Slewing Rings With Internal Gears

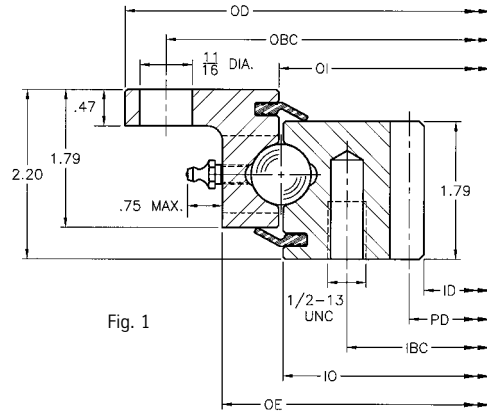

Fig. 1

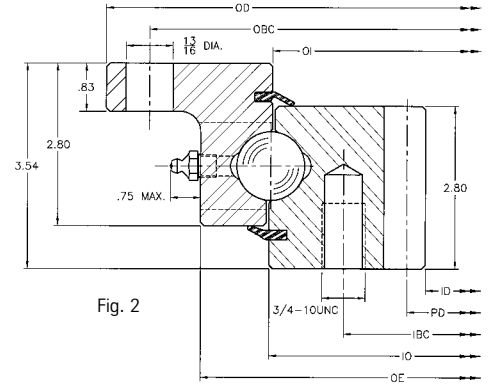

Fig. 2

Model No.	Wt. (lbs)	Outline Dimensions (inches)						Mounting Holes*				Gear Data			
		OD	ID	IO	OI	IE	OE	OBC (in)	No. Holes OBC	IBC (in)	No. Holes IBC	PD	DP 20° Stub	No. of Teeth	Max. Tangential ToothLoad
L6-16N9Z	59	20.39	12.85	16.24	16.36	—	17.83	19.25	8	14.88	12	13.25	4	53	6,090
L6-16N9ZD	59	20.39	12.85	16.24	16.36	—	17.83	19.25	16	14.88	12	13.25	4	53	6,090
L6-22N9Z	81	25.51	17.60	21.36	21.48	—	22.95	24.38	10	19.63	15	18.00	4	72	6,090
L6-22N9ZD	81	25.51	17.60	21.36	21.48	—	22.95	24.38	20	19.63	16	18.00	4	72	6,090
L6-25N9Z	96	29.45	21.60	25.30	25.41	—	26.89	28.38	12	23.63	18	22.00	4	88	6,090
L6-25N9ZD	96	29.45	21.60	25.30	25.41	—	26.89	28.38	24	23.63	18	22.00	4	88	6,090
L6-29N9Z	112	33.39	25.60	29.23	29.35	—	30.83	32.25	15	27.63	18	26.00	4	104	6,090
L6-29N9ZD	112	33.39	25.60	29.23	29.35	—	30.83	32.25	24	27.63	20	26.00	4	104	6,090
L6-33N9Z	133	37.32	29.13	33.17	33.29	—	34.76	36.25	18	31.50	18	29.67	3	89	8,120
L6-33N9ZD	133	37.32	29.13	33.17	33.29	—	34.76	36.25	28	31.50	20	29.67	3	89	8,120
L6-37N9Z	144	41.26	33.13	37.11	37.22	—	38.70	40.13	18	35.50	20	33.67	3	101	8,120
L6-37N9ZD	144	41.26	33.13	37.11	37.22	—	38.70	40.13	32	35.50	22	33.67	3	101	8,120
L6-43N9Z	167	47.17	39.13	43.01	43.13	—	44.61	46.00	18	41.50	24	39.67	3	119	8,120
L6-43N9ZD	167	47.17	39.13	43.01	43.13	—	44.61	46.00	32	41.50	24	39.67	3	119	8,120
Tolerances		±.14	+.03	±.14	±.14		±.14								
L9-38N9Z	351	43.31	32.16	37.66	37.54	—	40.04	41.75	30	35.00	30	32.80	2.5	82	15,400
L9-42N9Z	388	47.24	36.16	41.59	41.48	—	43.98	45.75	30	39.00	30	36.80	2.5	92	15,400
L9-46N9Z	433	51.18	39.76	45.53	45.41	—	47.91	49.75	36	43.00	36	40.40	2.5	101	15,400
L9-49N9Z	467	55.12	43.76	49.47	49.35	—	51.85	53.63	42	47.00	42	44.40	2.5	111	15,400
L9-53N9Z	505	59.06	47.76	53.41	53.29	—	55.79	57.63	42	51.00	42	48.40	2.5	121	15,400
L9-57N9Z	538	62.99	51.76	57.34	57.22	—	59.72	61.50	48	55.00	48	52.40	2.5	131	15,400
Tolerances		±.14	+.03	±.14	±.14		±.14								

Model numbers beginning with L9 have six equally spaced grease fittings; all others listed have four.

\*Thread depth on L6 slewing ring: 0.75 inches. Thread depth on L9 slewing rings: 1.13 inches.

Gear tooth hardness 180 BHN minimum.

Rotek recommends consulting pages 12 - 36 for additional information that must be reviewed prior to slewing ring selection.

# Series 2100 Econo-Trak® Slewing Rings With External Gears

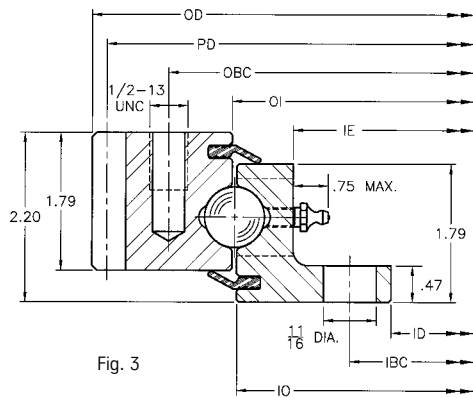

Fig. 3

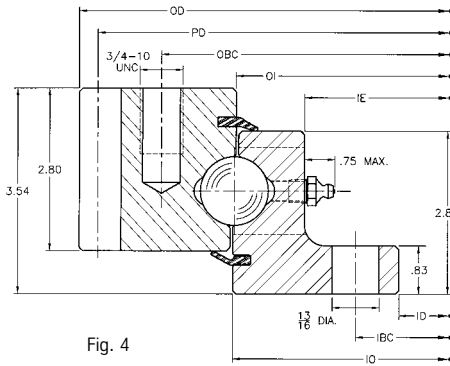

Fig. 4

Model No.	Wt. (lbs)	Outline Dimensions (inches)						Mounting Holes*				Gear Data			
		OD	ID	IO	OI	IE	OE	OBC (in)	No. Holes OBC	IBC (in)	No. Holes IBC	PD	DP 20° Stub	No. of Teeth	Max. Tangential ToothLoad
L6-16E9Z	65	19.90	11.97	16.24	16.36	14.76	—	18.00	8	13.13	12	19.50	4	78	5,740
L6-16E9ZD	65	19.90	11.97	16.24	16.36	14.76	—	18.00	10	13.13	24	19.50	4	78	5,740
L6-22E9Z	86	25.15	17.09	21.36	21.48	19.88	—	23.25	12	18.13	15	24.75	4	99	5,852
L6-22E9ZD	86	25.15	17.09	21.36	21.48	19.88	—	23.25	14	18.13	28	24.75	4	99	5,852
L6-25E9Z	103	29.15	21.02	25.30	25.41	23.82	—	27.25	15	22.13	18	28.75	4	115	5,894
L6-25E9ZD	103	29.15	21.02	25.30	25.41	23.82	—	27.25	16	22.13	32	28.75	4	115	5,894
L6-29E9Z	115	32.90	24.96	29.23	29.35	27.76	—	31.00	18	26.13	18	32.50	4	130	5,950
L6-29E9ZD	115	32.90	24.96	29.23	29.35	27.76	—	31.00	18	26.13	32	32.50	4	130	5,950
L6-33E9Z	137	37.20	28.90	33.17	33.29	31.69	—	35.00	18	30.00	18	36.67	3	110	7,840
L6-33E9ZD	137	37.20	28.90	33.17	33.29	31.69	—	35.00	18	30.00	36	36.67	3	110	7,840
L6-37E9Z	153	41.20	32.83	37.11	37.22	35.63	—	38.88	18	34.00	20	40.67	3	122	7,896
L6-37E9ZD	153	41.20	32.83	37.11	37.22	35.63	—	38.88	20	34.00	40	40.67	3	122	7,896
L6-43E9Z	170	46.87	38.74	43.01	43.13	41.54	—	44.63	20	39.88	24	46.33	3	139	7,952
L6-43E9ZD	170	46.87	38.74	43.01	43.13	41.54	—	44.63	22	39.88	40	46.33	3	139	7,952
Tolerances		-.03	±.10	±.14	±.14	±.14									
L9-38E9Z	360	43.04	31.69	37.66	37.54	35.16	—	40.00	30	33.25	30	42.40	2.5	106	14,700
L9-42E9Z	404	47.04	35.63	41.59	41.48	39.09	—	44.00	30	37.13	30	46.40	2.5	116	14,770
L9-46E9Z	445	51.04	39.57	45.53	45.41	43.03	—	48.00	36	41.13	36	50.40	2.5	126	14,840
L9-49E9Z	485	55.04	43.50	49.47	49.35	46.97	—	52.00	42	45.00	42	54.40	2.5	136	14,910
L9-53E9Z	529	59.04	47.44	53.41	53.29	50.91	—	56.00	42	49.00	42	58.40	2.5	146	14,980
L9-57E9Z	541	62.64	51.38	57.34	57.22	54.84	—	59.63	48	52.88	48	62.00	2.5	155	15,050
Tolerances		-.03	±.14	±.14	±.14	±.14									

Model numbers beginning with L9 have six equally spaced grease fittings; all others listed have four.

\*Thread depth on L6 slewing ring: 0.75 inches. Thread depth on L9 slewing rings: 1.13 inches.

Gear tooth hardness 180 BHN minimum.

Rotek recommends consulting pages 12 - 36 for additional information that must be reviewed prior to slewing ring selection.



# Series 2100 Econo-Trak® Gearless Slewing Rings

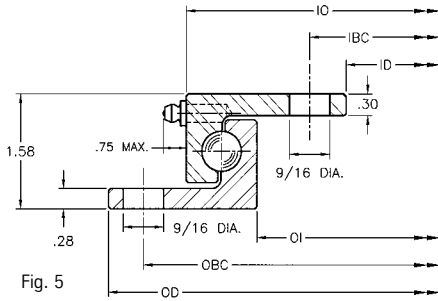

Fig. 5

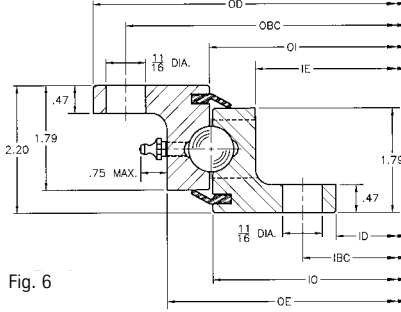

Fig. 6

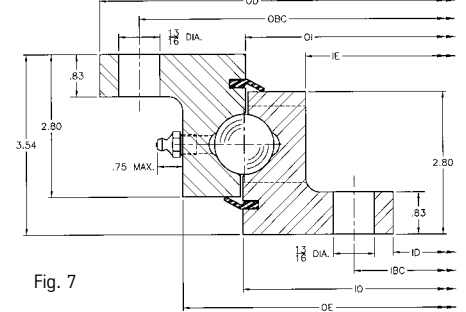

Fig. 7

	Model No.	Wt. (lbs)	Outline Dimensions (inches)					Mounting Holes*				
			OD	ID	IO	OI	IE	OE	OBC (in)	No. Holes OBC	IBC (in)	No. Holes IBC
Figure 5	L4-13P8Z**	30	15.79	9.17	13.70	11.73	—	—	14.88	8	10.25	8
	L4-13P9Z	30	15.79	9.17	13.70	11.73	—	—	14.88	8	10.25	8
	L4-17P8Z**	40	19.72	13.11	17.50	15.65	—	—	18.75	8	14.13	8
	L4-17P9Z	40	19.72	13.11	17.50	15.65	—	—	18.75	8	14.13	8
	Tolerances		±.10	±.10	±.10	±.10						
Figure 6	L6-16P9Z	52	20.39	11.97	16.24	16.36	14.76	17.83	19.25	8	13.13	12
	L6-16P9ZD	52	20.39	11.97	16.24	16.36	14.76	17.83	19.25	16	13.13	24
	L6-22P9Z	68	25.51	17.09	21.36	21.48	19.88	22.95	24.38	12	18.13	15
	L6-22P9ZD	68	25.51	17.09	21.36	21.48	19.88	22.95	24.38	20	18.13	28
	L6-25P9Z	80	29.45	21.02	25.30	25.41	23.82	26.89	28.38	12	22.13	18
	L6-25P9ZD	80	29.45	21.02	25.30	25.41	23.82	26.89	28.38	24	22.13	32
	L6-29P9Z	94	33.39	24.96	29.23	29.35	27.76	30.83	32.25	15	26.13	18
	L6-29P9ZD	94	33.39	24.96	29.23	29.35	27.76	30.83	32.25	24	26.13	32
	L6-33P9Z	105	37.32	28.90	33.17	33.29	31.69	34.76	36.25	18	30.00	18
	L6-33P9ZD	105	37.32	28.90	33.17	33.29	31.69	34.76	36.25	28	30.00	36
	L6-37P9Z	116	41.26	32.83	37.11	37.22	35.63	38.70	40.13	18	34.00	20
	L6-37P9ZD	116	41.26	32.83	37.11	37.22	35.63	38.70	40.13	32	34.00	40
	L6-43P9Z	135	47.17	38.74	43.01	43.13	41.54	44.61	46.00	18	39.88	24
	L6-43P9ZD	135	47.17	38.74	43.01	43.13	41.54	44.61	46.00	32	39.88	40
Tolerances		±.14	±.10	±.14	±.14	±.14	±.14	±.14				
Figure 7	L9-38P9Z	290	43.31	31.69	37.66	37.54	35.16	40.04	41.75	30	33.25	30
	L9-42P9Z	321	47.24	35.63	41.59	41.48	39.09	43.98	45.75	30	37.13	30
	L9-46P9Z	353	51.18	39.57	45.53	45.41	43.03	47.91	49.75	36	41.13	36
	L9-49P9Z	380	55.12	43.50	49.57	49.35	46.97	51.85	53.63	42	45.00	42
	L9-53P9Z	411	59.06	47.44	53.41	53.29	50.91	55.79	57.63	42	49.00	42
	L9-57P9Z	443	62.99	51.38	57.34	57.22	54.84	59.72	61.50	48	52.88	48
	Tolerances		±.14	±.14	±.14	±.14	±.14	±.14				

\*\*Models L4-13P8Z and L4-17P8Z are produced with unhardened raceways; all other models listed have induction hardened raceways. Model numbers beginning with L9 have six equally spaced grease fittings; all others listed have four.

\*9/16" holes for 1/2" bolts (L4 Models)  
 11/16" holes for 5/8" bolts (L6 Models)  
 13/16" holes for 3/4" bolts (L9 Models)  
 Rotek recommends consulting pages 12 - 36 for additional information that must be reviewed prior to slewing ring selection.

# Rotek® Standard Pinions for Econo-Trak® Series 2100 Slewing Rings

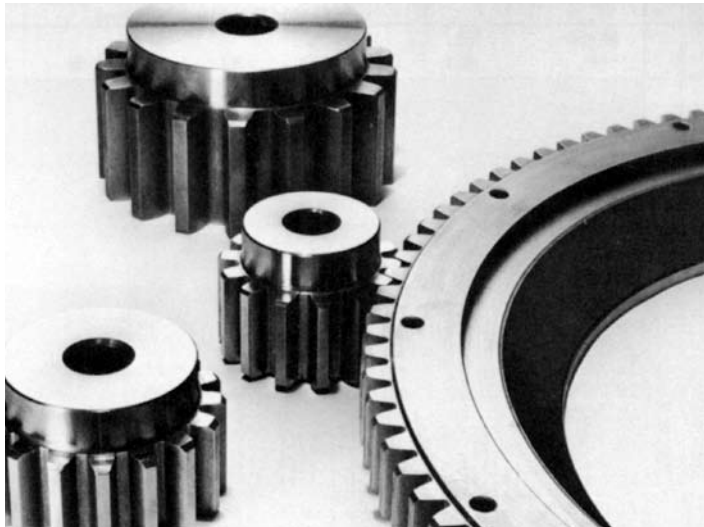

Econo-Trak slewing rings are equipped with 20° involute-stub gearing. Gear authorities favor this style of gearing for low-speed, heavily loaded applications because the teeth are stronger than those produced by other gear systems. Pinions with as few as 14 teeth are produced without weakening from undercutting.

It is essential that 20° involute-stub pinions be used with geared Econo-Trak slewing rings in order to provide proper gear performance.

Rotek pinions are produced from AISI 4140 steel, heat treated to 250-300 BHN. All surfaces are machined.

### Backlash

In order to provide greatest possible pinion tooth strength, Rotek pinions are produced with .000 to .006 backlash. Econo-Trak gears are cut with sufficient backlash to provide proper gear performance.

### Ordering Instructions

To order stock pinion: Rotek Pinion No. P4-3.5D2, Stock Bore.

(This pinion would be furnished with 1" bore as listed in the dimensional table, no keyway and no set screws.)

To order pinion with finished bore, keyway, and set screws:

Rotek Pinion No. P4-3.5D2, rebored to 1.625 bore, 3/8" x 3/16" keyway, two set screws. (This pinion would be furnished with one set screw over keyway, one at 90°.)

To order hubless pinion with tapered keyway:

Rotek Pinion No. P4-3.5D2 hub removed, rebored to 1.625 bore, with tapered keyway, 3/8" wide x 3/16" deep at deep end, taper 1/8" per foot (This pinion would be furnished without set screws.)

### Finished Bore and Keyway Standards

Standard pinions are furnished with stock bores, without keyways or set screws as stated in the dimensional table.

When desired, they may be rebored as required. Rebored pinions, unless otherwise specified, will be furnished with one standard keyway, with one set screw hole over the keyway, and with one set screw hole at 90°.

When pinions are ordered with hub removed, hub will be machined completely off and one straight keyway will be furnished, no set screws. Tapered keyways can be furnished when specified. Depth at large end is nominal depth from standard keyway.

### Standard Keyways

Shaft Diameter	Keyway
1" — 1-1/4"	1/4" x 1/8"
1-5/16" — 1-3/8"	5/16" x 5/32"
1-7/16" — 1-3/4"	3/8" x 3/16"
1-13/16" — 2-1/4"	1/2" x 1/4"
2-5/16" — 2-3/4"	5/8" x 5/16"
2-13/16" — 3-1/4"	3/4" x 3/8"
3-5/16" — 3-3/4"	7/8" x 7/16"

### Dimensions

For use with bearing models	DP	Face (F)	Hub Length (L)	No. teeth	PD	OD	Hub diameter	Stock bore	Model No.
L6-16 to L6-29	4	2.00	.88	14	3.500	3.90	2.88	1.000	P4-3.5D2
				17	4.250	4.65	3.63	1.000	P4-4.25D2
L6-33 to L6-43	3	2.00	.88	14	4.667	5.20	3.88	1.250	P3-4.67D2
				17	5.667	6.20	4.88	1.250	P3-5.67D2
L9-38 to L9-57	2.5	3.00	1.00	14	5.600	6.24	4.63	1.250	P2.5-5.6D2
				17	6.800	7.44	5.88	1.250	P2.5-6.8D2

Tolerance on stock bores is +0.001/-0.000".

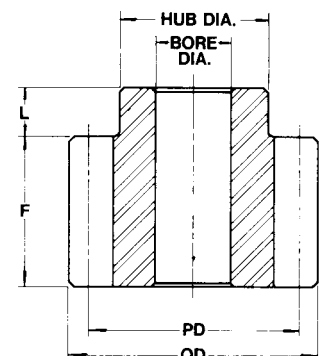

## Series 3000 Heavy Duty Slewing Rings

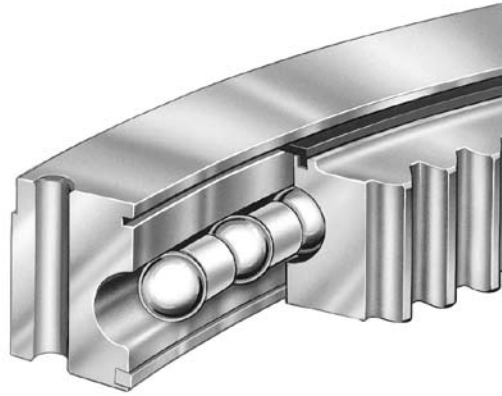

RoteK Series 3000 heavy duty slewing rings offer an optimum combination of economy, reliability and durability. An evolution of the classic four-point contact ball slewing ring design, these slewing rings incorporate an offset raceway construction, the highest possible degree of raceway wrap, and durable ball separators to provide an excellent platform for combined thrust, moment and radial loading.

The offset raceway keeps the load point at a constant distance from the edge of the raceway through rotation, making a high contact angle practical. This construction provides the most efficient utilization of the ball capacity in most applications.

To utilize full raceway wrap, balls are separated by individual spacers. Spacers and rolling elements are loaded into the raceway through a loading hole in one of the rings, which is filled with a closely-fitting plug conforming to the raceway contour.

Frictional torque is higher in four-point contact ball slewing rings than in other styles of combination load slewing rings.

## Available in Many Models

Here is a summary of the range of specifications that can be accommodated in Series 3000 models:

### Raceway Diameters:

- Standard models from 12" to 180"
- Special order slewing rings up to 360"

### Maximum Raceway Velocity:

700 feet per minute

### Maximum Loads:

(Standard models)

Thrust loads to 6,500,000 pounds

Moment loads to 21,000,000 foot-pounds

Radial loads to 1,200,000 pounds

☎ Contact Rotek for load information on special order models.

### Operating Temperatures:

Standard models to 175°F

Special models to 375°F

### Tolerances:

Available in standard or precision grades

Ideal for a Variety Of Heavy Duty Applications

Series 3000 slewing rings are ideal for a wide range of heavy duty slewing ring applications, including:

- Stationary and mobile cranes
- Excavators
- Aerial Lifts
- Industrial turntables
- Turnstiles
- Lift Truck Rotators
- Mining equipment
- Forestry equipment

## Dimensional Information for Series 3000 Slewing Rings with External Gears

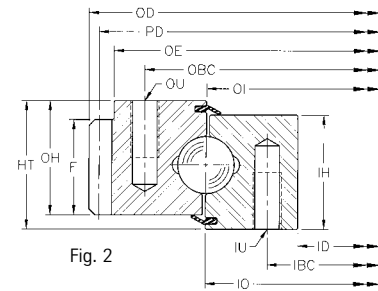
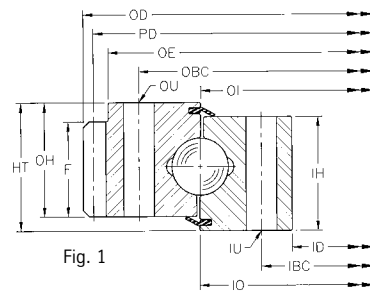

Model	Outline Dimensions (inches)									Nominal Capacity <sup>2</sup>	
	OD	ID	OE	OI	IO	HT	OH	IH	Weight (lbs)	Compressive Thrust (lbs)	Raceway Moment <sup>3</sup> (ft-lbs)
A6-9E1B	12.286	5.71	-	8.74	8.78	1.97	1.73	1.73	37	91,200	15,200
A6-11E4	14.685	8.27	14.02	11.48	11.28	1.97	1.73	1.73	45	111,500	24,200
A6-14E10	17.067	10.43	16.42	13.68	13.52	2.24	2.01	1.69	66	212,000	55,000
A8-17E10BC	20.484	12.77	-	16.81	16.38	2.13	2.06	2.06	101	320,000	101,000
A12-18E5	23.650	12.62	-	17.78	17.85	4.13	3.88	3.19	285	421,000	143,000
A14-18E1L <sup>1</sup>	23.250	12.88	-	17.78	17.86	3.44	3.25	3.25	252	618,000	210,000
A8-19E5A	23.900	15.12	-	19.11	19.14	2.50	2.18	2.18	140	369,000	135,000
A8-22E6	26.286	18.36	25.50	22.15	21.70	2.25	2.13	2.13	154	309,000	130,000
A10-22E5A	27.314	17.38	-	21.54	21.59	3.31	2.94	2.94	240	570,000	234,000
A12-22E2	28.400	17.00	-	21.97	22.04	4.00	3.31	3.31	319	611,000	256,000
A14-22E1B <sup>1</sup>	28.400	17.13	-	22.03	22.11	3.44	3.25	3.25	319	461,000	194,000
A12-27E3	33.440	22.00	-	27.17	27.24	3.31	3.00	3.00	354	768,000	398,000
A8-30E8D	35.040	26.50	-	29.98	30.03	2.50	2.13	2.13	206	584,000	334,000
A10-34E6	39.400	29.50	38.38	33.97	34.03	3.88	3.03	3.03	387	899,000	583,000
A12-34E2AG	39.833	29.62	38.50	34.09	34.16	3.25	2.88	2.88	390	635,000	413,000
A14-34E31	38.650	28.25	37.50	33.59	33.67	4.92	4.53	3.75	557	1,150,000	735,000
A13-38E1	45.600	32.53	43.50	37.96	38.04	4.63	3.38	4.25	669	1,230,000	893,000
A8-39E12	42.598	34.88	41.04	38.27	38.62	3.23	2.87	2.64	310	461,000	339,000
A8-41E1	46.640	36.29	-	40.92	40.81	3.50	3.00	2.62	456	803,000	627,000
A12-42E3	48.533	36.75	47.18	41.97	42.04	4.00	3.50	3.50	688	1,190,000	953,000
A18-46E4D	55.000	39.03	52.44	45.80	45.90	4.75	4.38	4.38	1186	1,720,000	1,510,000
A10-47E1	54.300	42.00	52.25	47.22	47.28	4.63	3.63	3.63	783	1,150,000	1,030,000
A12-48E12	54.240	43.00	52.38	47.72	47.79	4.00	3.38	3.50	720	895,000	815,000
A14-48E22	56.240	41.38	-	47.96	48.04	4.75	3.85	4.40	1170	1,750,000	1,600,000
A16-53E1A	61.300	47.12	59.25	53.27	53.36	5.88	4.69	4.69	1540	2,000,000	2,030,000
A18-60E2	68.800	51.75	66.75	59.45	59.55	5.50	5.13	5.13	1972	2,230,000	2,530,000
A18-74E3	84.571	65.50	81.54	73.95	74.05	7.00	5.44	6.19	2940	2,790,000	3,940,000
A16-78E4	86.800	71.31	84.47	77.85	77.94	5.00	4.50	4.50	2033	1,670,000	2,480,000
A18-80E1	91.199	69.50	88.62	79.45	79.55	7.00	6.50	6.50	4806	3,010,000	4,570,000
A18-89E1	99.800	78.38	-	88.45	88.55	6.62	6.00	6.00	4381	3,360,000	5,660,000
A22-105E2A	117.082	95.06	-	104.94	105.06	6.00	5.63	5.63	4773	3,810,000	7,630,000
A19-111E1	122.079	103.70	119.13	110.78	110.88	5.04	4.65	4.65	3565	4,220,000	8,920,000
A24-119E11A	129.067	111.19	-	118.77	118.91	6.75	6.50	5.88	5050	3,700,000	8,390,000
A16-152E2	162.519	145.08	159.45	151.77	152.88	6.50	5.51	5.51	5734	5,750,000	16,600,000

<sup>1</sup>Seal is shipped loose with slewing ring. % Contact Rotek for details.

<sup>2</sup>Capacity ratings are static, non-simultaneous maximums at raceway service factor = 1.00. Consult pages 12 - 36.

<sup>3</sup>Caution: The number of mounting holes may limit maximum rated moment loads! %

Note: Catalog illustrations are present general boundary dimensions and mounting hole styles. Features details may vary from the sketch shown. %

Rotek recommends consulting pages 12 - 36 for additional information that must be reviewed prior to slewing ring selection.

# Dimensional Information for Series 3000 Slewing Rings with External Gears

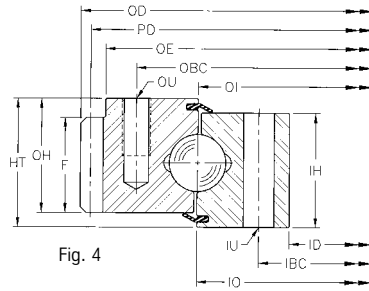
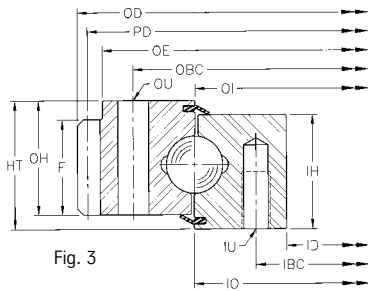

Model	Mounting Holes						Gear Data						
	OBC	OU	No. of OBC Holes	IBC	IU	No. of IBC Holes	Hole Figure Style	PD	DP	No. of Teeth	Tooth Form	F	Tangential Gear Capacity (lbs)
A6-9E1B	10.630	5/8-11	16	6.890	5/8-11	16-1	2	12.000	5	60	20d, 5/7 Fellows	1.73	6200
A6-11E4	13.189	5/8-11	16	9.449	5/8-11	20	2	14.400	5	72	20d, 5/7 Fellows	1.50	6000
A6-14E10	15.354	5/8-11	18	11.614	5/8-11	24	2	16.800	5	84	20d, 5/7 Fellows	1.73	6800
A8-17E10BC	18.874	5/8-11	20	14.374	5/8-11	20	2	20.200	5	101	20d, 5/7 Fellow	2.06	7700
A12-18E5	21.250	3/4-10	18	14.375	.94	24-1	4	23.250	4	93	20d, Stub	3.88	17100
A14-18E1L	21.250	3/4-16	18	14.375	3/4-16	24-1	2	23.250	4	93	20d, Stub	3.25	14300
A8-19E5A	21.500	3/4-10 <sup>1</sup>	20	16.625	.81	24-1	4	23.500	4	94	20d, Stub	2.18	10200
A8-22E6	24.500	5/8-11	18	19.500	5/8-11	18	2	26.000	5	130	20d, 5/7 Fellows	2.00	7600
A10-22E5A	24.375	3/4-10 <sup>1</sup>	30	18.750	3/4-10 <sup>1</sup>	30-1	2	26.857	3.5	94	20d, Stub	2.94	14800 <sup>5</sup>
A12-22E2	25.378	7/8-9 <sup>1</sup>	24	18.618	.94	30-2	4	28.000	4	112	20d, 4/5 Fellow	3.31	14800
A14-22E1B	25.380	.78 <sup>2</sup>	18	18.630	.78 <sup>2</sup>	24-1	1	28.000	4	112	20d, Stub	3.25	14500
A12-27E3	30.250	3/4-10	28	23.875	.81	28	4	32.800	2.5	82	20d, Full Depth <sup>4</sup>	3.00	22300 <sup>5</sup>
A8-30E8D	32.250	.69	24	27.750	.69	28	1	34.400	2.5	86	20d, Stub	2.13	16300 <sup>5</sup>
A10-34E6	36.750	.81	36	31.250	.81	40-1	1	39.000	4	156	20d, 4/5 Fellows	2.75	12500
A12-34E2AG	37.125	3/4-10	30	31.125	3/4-10	36	2	39.333	3	118	20d, 3/4 Fellows	2.50	15300
A14-34E31	35.750	1-8	24	30.000	1.13	30-1	4	38.250	4	153	20d, 4/5 Fellow	3.27	15700
A13-38E1	41.500	1.06	28	34.500	1.06	35 <sup>3</sup>	1	44.800	2.5	112	20d, Full Depth	2.88	18100
A8-39E12	39.961	M16x2	30	36.299	M16x2 <sup>1</sup>	30	2	41.260	3.175	131	20d, 8 Module <sup>4</sup>	2.87	14400 <sup>5</sup>
A8-41E1	43.500	.94	36	37.875	.94	36	1	46.000	2.5	115	20d, Stub	3.00	24000
A12-42E3	45.250	1.00-8	36	38.750	1-8	42-1	2	48.000	3	144	20d, Stub	2.75	17600
A18-46E4D	50.250	1.31	27	41.375	1.31	36-1	1	54.000	2	108	20d, Full Depth	4.00	31400
A10-47E1	50.375	1.06	30	44.125	1.06	36	1	53.500	2	107	20d, Stub	3.00	26700
A12-48E12	50.790	.94	36	44.690	.94	36	1	53.600	2.5	134	20d, Stub	3.25	23400
A14-48E22	52.000	1.25-7	36	44.000	1.25-7	36	2	55.600	2.5	139	20d, Stub	3.85	27800
A16-53E1A	57.375	1.06	40	49.250	1.06	45-1	1	60.500	2	121	20d, Stub	4.00	35800
A18-60E2	64.250	1.25-7	54	54.500	1.25-7	54-1	2	68.000	2	136	20d, Stub	3.75	35800
A18-74E3	78.625	1.38	60	68.750	1.38	52 <sup>3</sup>	1	83.429	1.75	146	25d, Full Depth	4.38	49100
A16-78E4	82.125	1.31	48	73.688	1.31	48	1	86.000	2	172	20d, Stub	4.00	36500
A18-80E1	85.500	1.50-6	48	73.000	1.50-6	52-1	2	90.286	1.75	158	20d, Stub	5.00	55000
A18-89E1	94.250	1.50-6 <sup>1</sup>	60	82.500	1.50-6 <sup>1</sup>	60	2	99.000	2	198	20d, Stub	6.00	58300
A22-105E2A	110.500	1.50-6 <sup>1</sup>	60	99.500	1.50-6 <sup>1</sup>	60-1	2	116.000	1.5	174	20d, Stub	5.63	72600
A19-111E1	115.354	1.30	56	106.299	1.30	56	1	120.315	1.5875	191	20d, 16 Module <sup>4</sup>	4.53	46200 <sup>5</sup>
A24-119E11A	124.250	1.34	44	113.688	1.34	44	1	128.000	1.5	192	20d, Stub	6.50	84100
A16-152E2	155.709	1.09	60	147.244	1.09	60	1	160.630	1.5875	255	20d, 16 Module <sup>4</sup>	4.53	46700

1Counter drilled for extra bolt stretch length ☎ Contact Rotek for details.

2Counter bored for socket head cap screws. ☎

3Mounting holes unequally spaced. ☎

4Corrected gear tooth profile. ☎

5Gear teeth induction hardened for wear resistance. ☎

Note: The catalog listing is only a small representation of the models available. Numerous larger, smaller and intermediate sized models are available that are not cataloged here. ☎ Call your local Rotek Sales Engineer or the Rotek Application Engineering Department at 800/221-8043 for information on non-cataloged models.

# Dimensional Information for Series 3000 Slewing Rings with Internal Gears

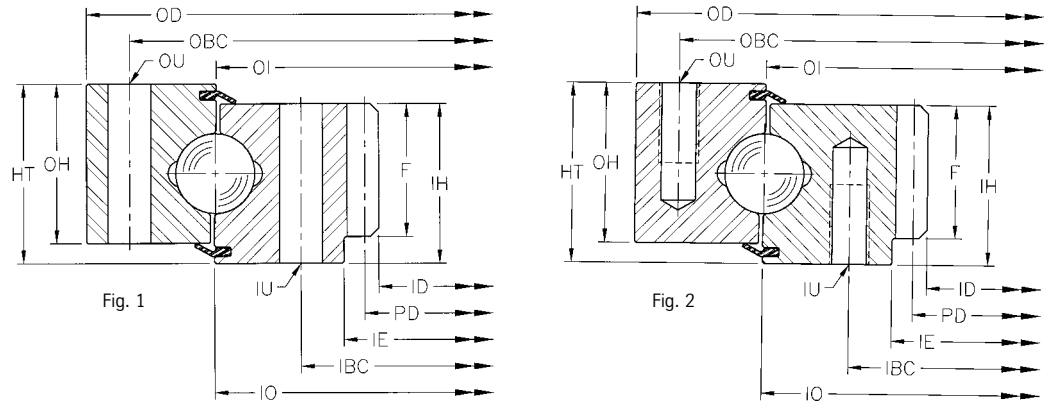

Model	Outline Dimensions (inches)								Nominal Capacity <sup>2</sup>		
	OD	ID	IE	OI	IO	HT	OH	IH	Weight (lbs)	Compressive Thrust (lbs)	Raceway Moment <sup>3</sup> (ft-lbs)
A8-17N4D	20.48	12.748	-	16.81	16.40	2.13	2.06	2.06	101	269,000	85,000
A8-22N2A	25.75	16.850	-	22.03	22.06	2.75	2.38	2.38	184	309,000	130,000
A8-25N2 <sup>1</sup>	28.75	21.350	22.38	24.99	25.02	3.50	2.88	3.38	228	350,000	167,000
A9-25N3	28.75	19.543	20.75	24.72	24.78	3.38	2.63	3.00	242	529,000	250,000
A10-32N1A	36.75	26.400	-	31.97	32.03	3.86	3.00	3.50	405	775,000	473,000
A14-33N1	38.59	24.960	26.50	32.46	32.38	4.38	3.50	4.00	557	1,170,000	723,000
A10-35N1L	39.00	30.966	32.12	35.31	35.34	4.50	3.38	3.56	375	749,000	505,000
A12-35N5	39.47	30.400	31.88	35.28	35.35	5.00	4.00	4.00	486	1,140,000	770,000
A7-38N1	41.75	33.110	34.59	37.87	37.91	2.17	1.89	1.89	232	490,000	354,000
A10-43N28D	46.25	37.680	39.80	42.80	42.86	4.25	3.38	3.75	448	739,000	603,000
A13-46N1A	51.13	39.760	-	45.81	45.88	4.19	3.62	3.81	722	1,480,000	1,300,000
A12-47N3E	52.75	41.760	43.50	47.40	47.47	4.78	3.88	4.13	783	1,360,000	1,230,000
A14-47N5A	52.00	41.280	42.97	46.71	46.79	5.06	3.62	4.69	770	1,680,000	1,500,000
A9-54N2	58.62	47.831	50.10	54.10	54.18	4.72	3.54	4.09	925	1,360,000	1,400,000
A14-54N10C	60.00	46.700	48.62	54.22	54.30	5.50	4.50	4.50	1150	1,960,000	2,030,000
A16-56N5	61.62	46.884	-	55.70	55.79	5.25	4.50	4.25	1295	2,100,000	2,230,000
A16-59N2	66.22	49.700	52.27	59.21	59.30	4.25	3.88	3.88	1400	2,230,000	2,520,000
A20-72N5A	79.94	61.600	64.25	71.95	72.06	5.12	4.75	4.75	2159	2,680,000	3,680,000
A18-80N1	89.00	70.267	-	80.20	80.30	4.88	4.50	4.50	2425	3,040,000	4,660,000
A16-95N6	100.25	88.960	-	95.27	95.36	5.00	4.50	4.50	1825	1,440,000	2,630,000
A20-95N4	103.00	84.700	86.75	94.95	95.06	7.25	6.88	6.88	4400	3,540,000	6,410,000
A24-107N1	117.00	93.600	96.13	106.43	106.57	6.00	5.62	5.62	5437	3,330,000	6,770,000
A22-129N1	137.75	116.933	-	128.56	128.69	6.25	5.88	5.88	5601	6,510,000	16,000,000
A22-166N1	176.38	153.600	157.00	166.14	165.86	9.50	9.00	9.00	13061	3,860,000	12,200,000

<sup>1</sup>Seal on one side only. ☒ Contact Rotek for details.

<sup>2</sup>Capacity ratings are static, non-simultaneous maximums at raceway service factor = 1.00. Consult pages 12 - 36.

<sup>3</sup>Caution: The number of mounting holes may limit maximum rated moment loads! ☒ Contact Rotek for details.

Note: Catalog illustrations represent general boundary dimensions and mounting hole styles. Features details may vary from the sketch shown.

☒ Contact Rotek for details.

Rotek recommends consulting pages 12 - 36 for additional information that must be reviewed prior to slewing ring selection.

# Dimensional Information for Series 3000 Slewing Rings with Internal Gears

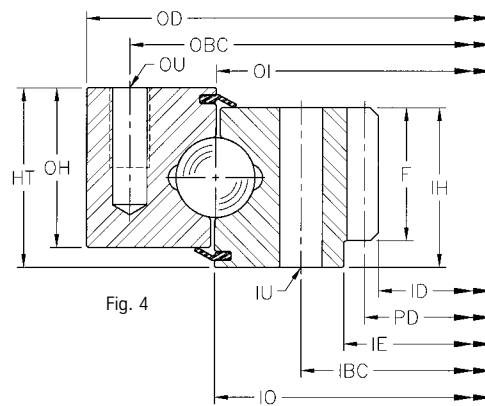
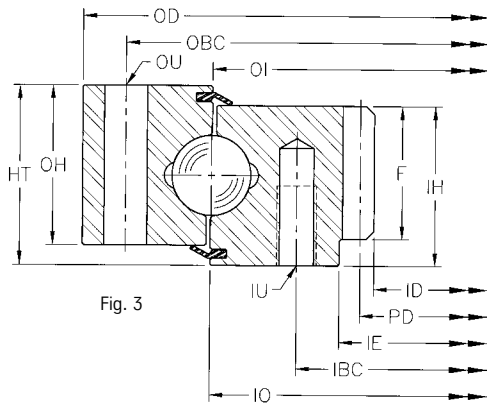

Model	Mounting Holes							Gear Data					
	OBC	OU	No. of OBC Holes	IBC	IU	No. of IBC Holes	Hole Fig. Style	PD	DP	No. of Teeth	Tooth Form	F	Tangential Gear Capacity (lbs)
A8-17N4D	18.875	5/8-11	20	14.375	5/8-11	20	2	13.000	5	65	20d, 5/7 Fellows	2.06	9,200
A8-22N2A	24.500	.69	18	19.500	5/8-11	24	3	17.250	4	69	20d, Stub	2.38	12,600
A8-25N2	27.375	5/8-11	18	23.625	5/8-11	18	2	21.750	4	87	20d, Stub	2.00	10,600
A9-25N3	27.250	.81	30	22.250	3/4-10	36	3	20.000	3.5	70	20d, Stub	2.88	19,500
A10-32N1A	35.000	1.06	24	29.187	1.00-8	26	3	26.857	3.5	94	20d, Stub	3.50	22,400
A14-33N1	36.313	1.25	36-1	28.688	1.25	36	1	25.600	2.5	64	20d, Stub	3.50	29,600 <sub>5</sub>
A10-35N1L	37.170	3/4-10	30	33.460	3/4-10	30	2	31.429	3.5	110	20d, Stub	2.00	12,100
A12-35N5	37.170	7/8-9	36	33.460	7/8-9	36	2	30.857	3.5	108	20d, Stub	3.00	19,200
A7-38N1	40.157	5/8-11 <sub>1</sub>	16	35.630	5/8-11 <sub>1</sub>	16	2	33.701	3.175	107	20d, 8 Module <sub>4</sub>	1.77	8,300
A10-43N28D	44.650	3/4-10	36	40.940	3/4-10	36	2	38.400	2.5	96	20d, Full Depth	2.75	21,900 <sub>5</sub>
A13-46N1A	49.125	1.06 <sub>2</sub>	30 <sub>3</sub>	43.000	1.00-8	22 <sub>3</sub>	3	40.400	2.5	101	20d, Stub	3.81	32,300
A12-47N3E	51.000	1.06	30	45.250	1.00-8	30	3	42.400	2.5	106	20d, Stub	3.00	25,400
A14-47N5A	50.375	.94	36	44.495	7/8-9	40	3	41.600	2.5	104	20d, Stub <sub>4</sub>	4.00	35,900 <sub>5</sub>
A9-54N2	56.850	.87	40	51.772	M20x2.5	40	3	47.717	2.1167	101	20d, 12 Module <sub>4</sub>	4.06	41,200 <sub>5</sub>
A14-54N10C	58.000	1.06	36	50.500	1.06	36	1	47.500	2	95	20d, Stub	3.25	34,400
A16-56N5	59.750	1.06	42	51.750	1.06	42	1	47.429	1.75	83	25d, Full Depth <sub>4</sub>	4.25	48,000 <sub>5</sub>
A16-59N2	63.500	1.31	38	55.000	1.31	36	1	50.667	1.5	76	20d, Stub	3.50	69,200
A20-72N5A	77.060	1.63	48-1	66.940	1.63	48	1	62.667	1.5	94	20d, Stub	3.75	56,100
A18-80N1	85.000	1.56	60-1	75.500	1.56	60	1	71.333	1.5	107	20d, Stub	4.50	67,300
A16-95N6	98.750	3/4-10	12	91.875	3/4-10	12	2	89.600	2.5	224	20d, Stub	4.50	38,100
A20-95N4	100.000	1.38	90-1	90.000	1.25-7	90	3	85.500	2	171	20d, Stub	5.00	56,100
A24-107N1	113.000	1.31	48-1	100.000	1.31	48	1	94.667	1.5	142	20d, Stub	4.75	67,100
A22-129N1	134.000	1.50-6 <sub>1</sub>	90-1	123.250	1.50-6 <sub>1</sub>	100	2	118.000	1.5	177	20d, Stub	5.88	88,000
A22-166N1	173.250	1.25-7	90	159.625	1.25-7	90	2	154.667	1.5	232	20d, Stub	5.75	77,900

1Counter drilled for extra bolt stretch length. ☎ Consult Rotek for details.

2Counter bored for socket head capscrews. ☎

3Mounting holes unequally spaced. ☎

4Corrected gear tooth profile. ☎

5Gear teeth induction hardened for wear resistance.

Note: The catalog listing is only a small representation of the models available. Numerous larger, smaller and intermediate sized models are available that are not cataloged here.

☎ Call your local Rotek Sales Engineer or the Rotek Application Engineering Department at 800/221-8043 for information on non-cataloged models.



# Dimensional Information for Series 3000 Gearless Slewing Rings

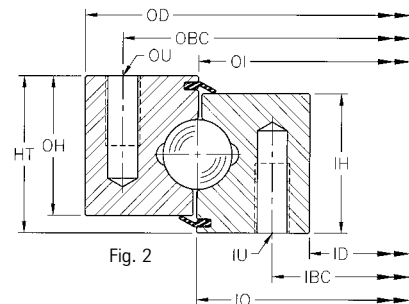
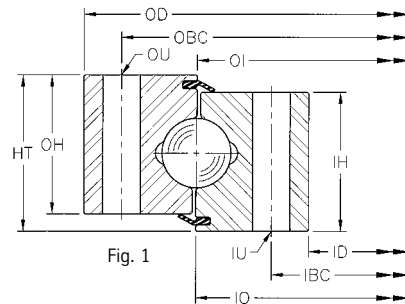

Model	Outline Dimensions (inches)							Nominal Capacity <sup>1</sup>		
	OD	ID	OI	IO	HT	OH	IH	Weight (lbs)	Compressive Thrust (lbs)	Raceway Moment <sup>2</sup> (ft-lbs)
A6-9P4	11.81	5.71	8.86	8.70	1.81	1.61	1.61	32	91,200	15,300
A6-11P5	14.68	8.26	11.64	11.17	1.57	1.50	1.50	43	173,000	37,500
A6-14P3D	16.54	10.43	13.46	13.50	1.97	1.73	1.73	56	80,000	20,600
A8-17P1DU	20.48	12.74	16.81	16.38	2.13	2.06	2.06	101	320,000	101,000
A14-19P4	24.13	13.63	18.84	18.92	3.81	3.44	3.44	264	550,000	198,000
A8-22P11	26.00	18.00	21.98	22.02	2.75	2.38	2.38	170	309,000	130,000
A13-22P4	27.50	16.63	21.96	22.04	3.50	3.13	3.13	275	697,000	292,000
A4-23P2A	26.00	20.00	22.99	23.01	1.82	1.53	1.53	83	109,000	47,800
A9-24P2	27.97	19.77	23.85	23.90	2.88	2.50	2.50	188	426,000	194,000
A14-24P1A	28.75	19.12	23.96	24.04	3.62	3.25	3.25	294	499,000	228,000
A14-25P1	31.83	18.75	25.08	25.17	4.38	4.00	3.50	475	898,000	430,000
A14-31P3	35.75	26.00	31.02	31.10	3.81	3.44	3.44	406	1,100,000	653,000
A12-32P2	36.25	27.13	31.47	31.54	3.25	2.88	2.88	316	893,000	536,000
A12-34P2B	39.80	29.65	34.09	34.16	3.25	2.88	2.88	426	635,000	413,000
A10-35P1A	39.00	32.12	35.31	35.34	4.50	3.38	3.56	349	604,000	406,000
A14-43P1	48.25	38.13	43.16	43.24	3.81	3.44	3.44	605	1,540,000	1,270,000
A12-47P2	52.75	41.76	47.40	47.47	4.78	3.88	4.13	824	1,360,000	1,230,000
A14-49P1A	53.62	43.38	48.46	48.54	4.19	3.81	3.81	703	1,010,000	935,000
A14-56P1E	61.64	49.50	55.77	55.85	5.34	4.52	4.09	1005	1,160,000	1,240,000
A18-60P1B	66.63	54.00	60.26	60.36	5.63	5.13	5.00	1593	1,360,000	1,570,000
A16-67P2	73.88	60.25	66.96	67.05	4.50	4.00	4.00	1442	2,530,000	3,230,000
A16-79P1A	84.75	72.75	78.71	78.79	4.25	3.88	3.88	1510	2,980,000	4,470,000
A16-86P1	91.00	80.00	85.46	85.55	6.00	4.75	4.75	1822	1,500,000	2,430,000
A14-89P1	94.62	84.50	89.21	90.04	4.63	4.25	3.62	1476	1,270,000	2,170,000
A18-89P1	96.50	82.28	88.95	89.05	6.30	4.76	5.91	2623	2,030,000	3,440,000
A22-98P1	105.75	90.17	97.98	98.11	5.76	5.38	5.38	3204	2,770,000	5,180,000
A10-110P2D	114.25	105.75	109.97	110.03	3.00	2.62	2.62	981	1,910,000	4,000,000
A12-125P1	129.92	119.33	124.73	124.77	5.50	4.00	4.50	2400	2,350,000	5,600,000
A19-150P1	157.52	141.69	149.55	149.66	5.04	4.64	4.64	4295	5,720,000	16,300,000

<sup>1</sup>Capacity ratings are static, non-simultaneous maximums at raceway service factor = 1.00. Consult pages 12 - 36.

<sup>2</sup>Caution: The number of mounting holes may limit maximum rated moment loads! ☎ Contact Rotek for details.

Note: Catalog illustrations represent general boundary dimensions and mounting hole styles. Features details may vary from the sketch shown. ☎

Rotek recommends consulting pages 12 - 36 for additional information that must be reviewed prior to slewing ring selection.

# Dimensional Information for Series 3000 Gearless Slewing Rings

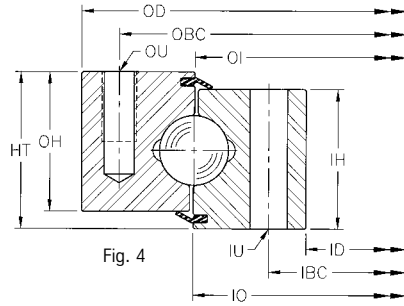
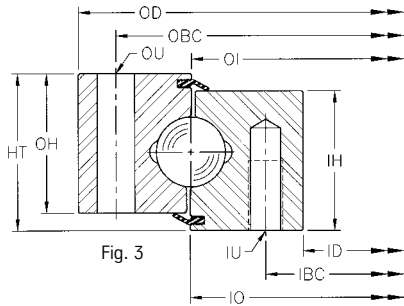

Mounting Holes							
Model	OBC	OU	No. of OBC Holes	IBC	IU	No. of IBC Holes	Hole Fig. Style
A6-9P4	10.630	.66	10	6.890	.66	10	1
A6-11P5	13.189	1/2-13	16	9.449	1/2-13	20-1	2
A6-14P3D	15.354	5/8-11	18	11.614	.66	24-1	4
A8-17P1DU	18.875	5/8-11	20	14.375	5/8-11	20	2
A14-19P4	22.438	.97	24-1	15.312	7/8-9 <sup>1</sup>	24	3
A8-22P11	24.500	.78	20	19.500	3/4-10	20	3
A13-22P4	25.375	1.06	24	18.625	1.06	24	1
A4-23P2A	25.000	.53	12	21.000	1/2-13	12	2
A9-24P2	26.625	3/4-10	30	21.125	3/4-10	30	2
A14-24P1A	27.375	.81 <sup>2</sup>	30	20.625	.81 <sup>2</sup>	30-1	1
A14-25P1	29.000	1.31	27	21.250	1.31 <sup>2</sup>	23	1
A14-31P3	34.125	3/4-10	30-1	27.625	.78 <sup>2</sup>	30	4
A12-32P2	34.500	.81	40-1	28.500	3/4-10	40	3
A12-34P2A	37.000	.69 <sup>2</sup>	24	30.750	5/8-11	24	3
A10-35P1A	37.170	3/4-10	30	33.460	3/4-10	30	2
A14-43P1	46.625	.81	36	39.750	.81	36	1
A12-47P2	51.000	1.06	30	45.250	1.00-8	30	3
A14-49P1A	52.000	.94	50-1	45.000	.94	60	1
A14-56P1E	59.625	1.06	36	52.000	1.00-8	36	4
A18-60P1B	64.625	1.06	40	56.000	1.06	40	1
A16-67P2	71.250	1.31	60-1	62.750	1.25-7	60	3
A16-79P1A	82.750	1.00-8 <sup>1</sup>	32	74.750	1.00-8 <sup>1</sup>	32	2
A16-86P1	89.000	3/4-10	48	83.000	3/4-10	48	2
A14-89P1	92.500	3/4-10	20	86.000	.81	20	4
A18-89P1	93.504	1.30	48	84.449	1.30	48	1
A22-98P1	103.000	1.44	60-1	92.913	1.44	60	1
A10-110P2D	112.750	5/8-11	48	107.250	.72 <sup>1</sup>	48	4
A12-125P1	128.125	.94	36	121.250	.94	36	1
A19-150P1	154.488	1.50-6	72	144.750	1.63	72	4

<sup>1</sup>Counter drilled for extra bolt stretch length. ☎ Contact Rotek for details.  
<sup>2</sup>Counter bored for socket head capscrews.

Note: The catalog listing is only a small representation of the models available. Numerous larger, smaller and intermediate sized models are available that are not cataloged here. ☎ Call you local Rotek Sales Engineer or the Rotek Application Engineering Department at 800/221-8043 for information on non-cataloged models.

# Series 4000 Two Row Ball Slewing Rings



Series 4000 two-row ball slewing rings are designed for applications where mounting structures need to be relatively light in weight, for example, as in climbing cranes, tower cranes, and stacker cranes.

Series 4000 slewing rings are built with two sets of raceways and ball bearings. This design provides greater internal clearance and lower frictional torque, features that can compensate for the reduced accuracy and rigidity that can accompany a lighter mounting structure.

### Available in Many Models

Here is a summary of the range of specifications that can be satisfied with Rotek Series 4000 slewing rings:

Slewing Ring diameters:  
Domestic models from 12" to 180" O.D.

Maximum Raceway Velocity:  
700 feet per minute

Maximum Loads:  
(Standard Models)  
Thrust loads to 8,700,000 pounds  
Moment loads to 24,000,000 foot-pounds  
Radial loads to 860,000 pounds

**Contact Rotek for load information on special order models.**

Tolerances:  
Available in standard grades

Gearing:  
Internal or external gearing;  
or gearless

Note: These slewing rings are not typically inventoried. Contact Rotek for current lead times and requirement involving immediate availability.

### Ideal for Less Accurate or Rigid Mounting Structures

Series 4000 slewing rings have been used extensively in equipment that require relatively light mounting structures. Typical applications include:

- Climbing cranes
- Stackers/reclaimers
- Large industrial turntables
- Turnstiles
- Mining equipment
- Tower Cranes

### Capacity Curves

The raceway capacity charts can be used to select a Series 4000 model for specific application loads.

To use the charts, first calculate the net thrust and moment loads for the application. Next, multiple these figures by the appropriate recommended minimum service factor, (see page 19). Then plot the corrected thrust and moment loads on the appropriate chart. From the point where the plot lines intersect, select the slewing ring whose capacity is at, above, or to the right of the intersection point.

Bolt capacities may limit the raceway moment capacities shown.

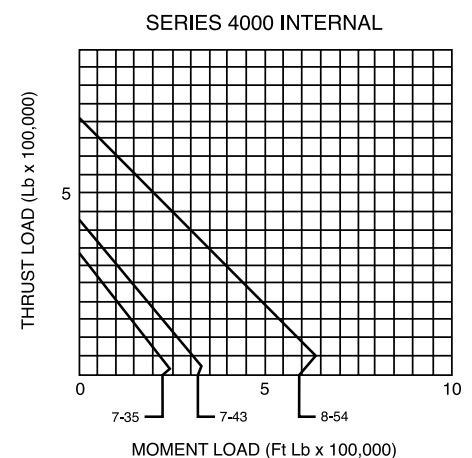
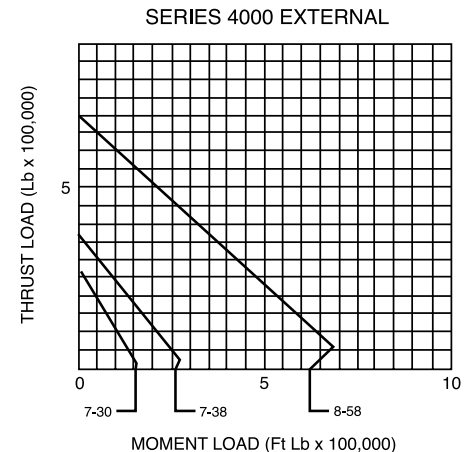

## External Gears

Outline Dimensions (inches)

Model	OD	ID	OE	OI	IO	HT	OH
H7-30E1	33.90	26.73	32.80	30.50	31.38	3.23	3.28
H7-38E1	42.50	35.27	41.00	38.90	39.84	3.23	2.28
H8-58E2	62.60	53.70	61.00	58.30	59.45	4.06	3.35

Gear Data

Mounting Holes

Nominal Capacity

Model	IH	K	PD	DP	Tooth Form 20°	F	No. of Teeth	Gear Hardness (BHN)	Max. allow. tang. tooth load (lbs)	OBC	OU	No. of Holes OBC	IBC	IU	No. of Holes IBC	Compressive Thrust (lbs)	Moment (ft-lbs)	Wt. (lbs)	Fig. no.
H7-30E1	3.07	.95	33.50	4	STUB	1.97	134	180-210	4650	31.50	5/8-11	24	27.80	5/8-11	24	273,000	160,000	230	1
H7-38E1	3.07	.95	42.00	3.5	STUB	1.97	147	180-210	5400	39.96	5/8-11	30	36.30	5/8-11	30	373,000	272,000	290	1
H8-58E2	3.94	.71	62.00	2.5	STUB	2.36	155	180-210	9100	59.53	3/4-10	40	55.12	3/4-10	40	670,000	633,800	750	1

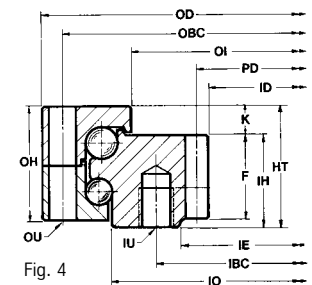
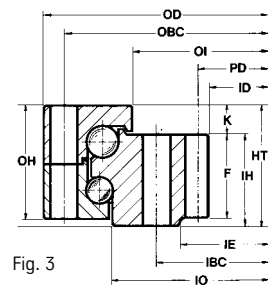
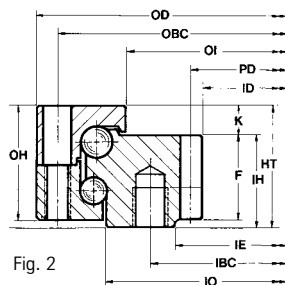
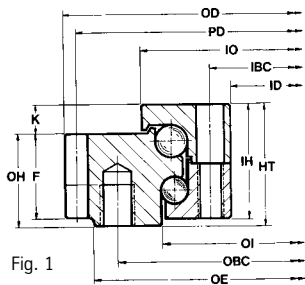

## Internal Gears

Outline Dimensions (inches)

Model	OD	ID	IE	OI	IO	HT	OH
H7-35N1	38.30	31.00	32.3	33.62	34.60	3.23	3.07
H7-43N1	45.80	37.70	39.8	41.10	42.10	3.54	3.07
H7-43N3A	45.80	37.80	—	41.10	42.10	3.84	3.07
H8-54N1	57.60	46.56	48.40	51.57	53.00	4.02	3.78

Gear Data

Mounting Holes

Nominal Capacity

Model	IH	K	PD	DP	Tooth Form 20°	F	No. of Teeth	Gear Hardness (BHN)	Max. allow. tang. tooth load (lbs)	OBC	OU	No. of Holes OBC	IBC	IU	No. of Holes IBC	Compressive Thrust (lbs)	Moment (ft-lbs)	Wt. (lbs)	Fig. no.
H7-35N1	2.28	.95	31.430	3.5	STUB	1.97	110	180-210	5250	37.17	5/8-11	30	33.46	5/8-11	30	338,000	230,000	270	2
H7-43N1	2.59	.95	38.400	2.5	F.D.	2.17	96	180-210	7100	44.65	5/8-11	36	40.94	5/8-11	36	412,000	333,000	350	2
H7-43N3A	2.60	.94	38.400	2.5	STUB	2.60	96	250-300	13000	44.65	.71	36	40.94	5/8-11	36	412,000	333,000	355	4
H8-54N1	3.04	.98	47.20	2.5	STUB	2.76	118	180-210	10330	56.10	.91	40	50.00	.91	40	683,000	588,000	760	3

Nominal capacity ratings are non-simultaneous maximums at raceway service factor = 1.00. Refer to the capacity curves for combined loading. Catalog illustrations are approximate. Seals, bolt spacing and other details may vary. Contact the Rotek Application Engineering Department for current drawings prior to doing significant layout and design.

Rotek recommends consulting pages 12 - 36 for additional information that must be reviewed prior to slewing ring selection. Numerous larger, smaller and intermediate sized standard models are available that are not cataloged here.

☎ Call your local Rotek Sales Engineer or the Rotek Application Engineering Department at 800/221-8043 for information on non-cataloged models.

## Series 5000 Cross Roller Heavy Duty Slewing Rings



The Rotek Series 5000 slewing ring is designed to sustain radial, thrust and moment loads which may occur individually or in combination.

To accomplish this universal load carrying capability, the Series 5000 slewing ring is manufactured with V-groove raceways that provide two roller paths in each ring. The rollers have a length slightly less than the diameter and are positioned between the rings in such a manner that adjacent rollers are at right angles to each other and contact opposing sets of raceways. By alternating rollers in this manner, one-half of the rollers transmit load in one direction and the other half transmit load in the other direction. The rolling elements are normally separated by individual spacers which occupy a minimum amount of space, permitting the use of nearly a full compliment of rollers.

The static thrust and moment capacity of a cross roller slewing ring is generally less than that of a comparable size four-point contact ball slewing ring, but has considerably higher radial load capacity. The Series 5000 cross roller slewing ring, however, offers the advantages of greater stiffness and a lower spring rate compared to a four-point contact ball slewing ring. These advantages make the cross roller slewing ring preferable in situations where deflection under load must be minimized, as in some machine tool applications. The greater resistance to deflection offered by the cross roller slewing ring requires that it be mounted to a mating surface that is properly engineered to accommodate its greater stiffness. When properly mounted, the cross roller slewing ring has a higher theoretical dynamic capacity per unit size than the single-row ball slewing ring.

### Available in Many Models

Here is a summary of the range or specifications that can be accommodated in Series 5000 models:

#### Slewing Ring Diameters:

Domestic models from 12" to 180" O.D.

#### Maximum Raceway Velocity:

700 feet per minute

#### Maximum Loads:

(Standard Models)

Thrust loads to 4,600,000 pounds

Moment loads to 16,000,000 foot-pounds

Radial loads to 2,200,000 pounds

#### Tolerances:

Available in standard or precision grades

% Contact Rotek for load information on special order models.

These slewing rings are not typically inventoried. Contact Rotek for current lead times and requirements involving immediate availability.

### Ideal for Demanding Applications

Series 5000 slewing rings have demonstrated excellent performance in a variety of applications where transmission of heavy loads with minimal deflection of the slewing ring is required:

- Machine tools
- Radar antennas
- Mining equipment
- Lift truck rotators
- Tunnel boring machines

# Series 5000 Load Capacities of Selected Models

## Capacity Curves

The raceway capacity charts at right can be used to select a Series 5000 model for specific application loads.

To use the charts, first calculate the net thrust and moment loads for the application. Next, multiply these figures by the appropriate recommended minimum service factor, (see page 19.) Then plot the corrected thrust and moment loads on the appropriate chart. From the point where the plot lines intersect, select the slewing ring whose capacity is at, above, or to the right of the intersection point.

For models not shown on the charts, consult the dimensional tables (page 63) for maximum nominal thrust and moment capacities. These models may be added to the charts below by simply drawing a line from the appropriate point on the thrust axis to the appropriate point on the moment axis, using the values listed in the dimensional tables. Bolt capacities may limit the raceway moment capacities shown.

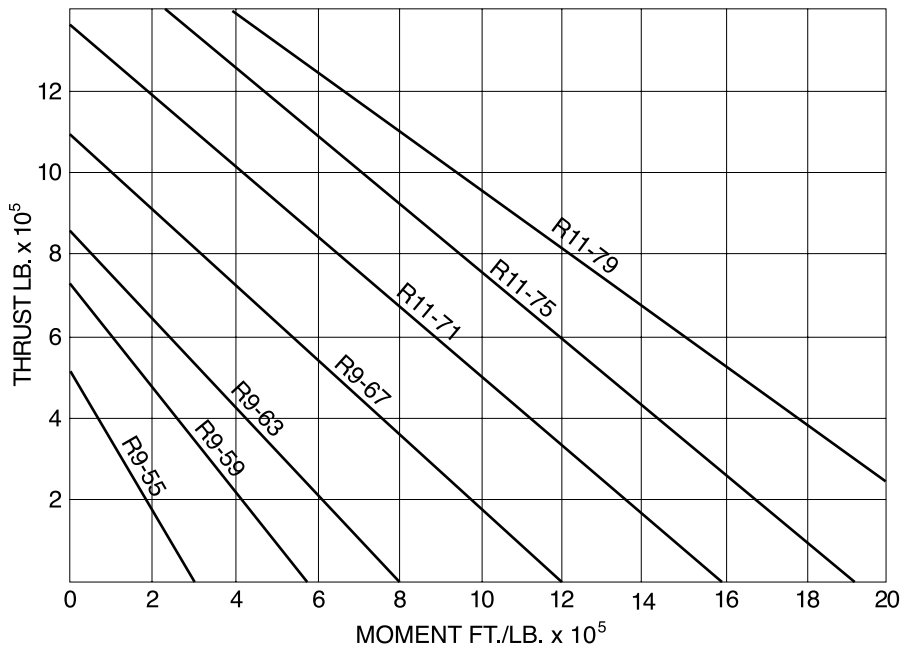
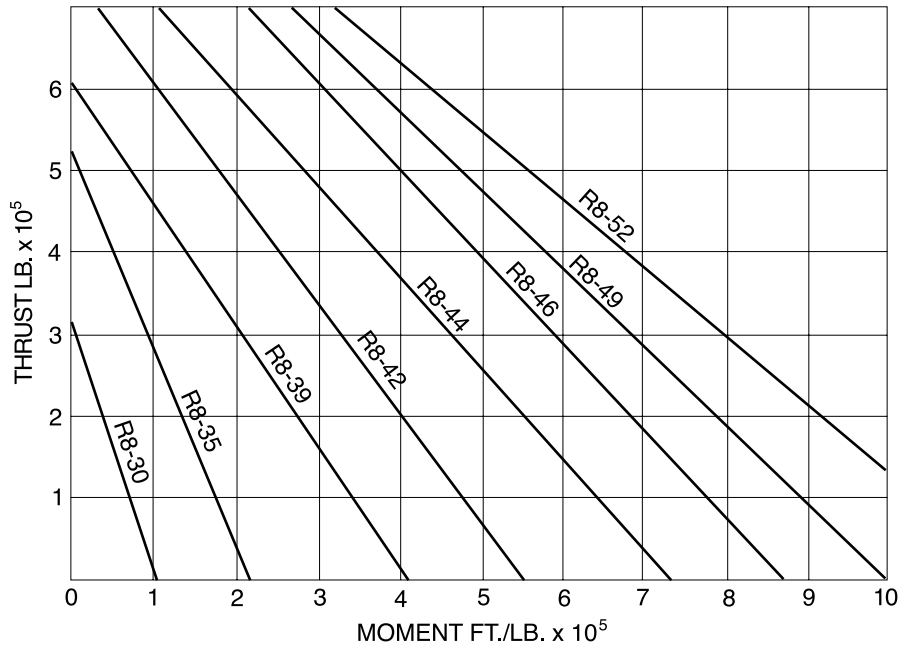

# Series 5000 Dimensional Information

## External Gears

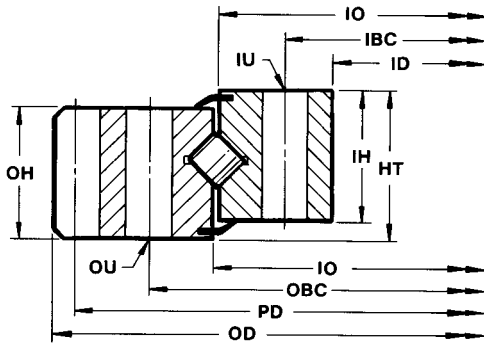

Outline Dimensions (inches)

Model	OD	ID	OI	IO	HT	OH	IH	PD	DP
R8-30E3	35.150	26.06	30.157	30.000	2.874	2.520	2.520	34.750	4
R8-35E3	40.533	30.87	34.961	34.803	2.874	2.520	2.520	40.000	3
R8-39E3	43.867	34.57	38.661	38.504	2.874	2.520	2.520	43.333	3
R8-42E3	48.240	38.39	42.480	42.323	2.874	2.520	2.520	47.600	2.5
R8-44E3	50.240	39.69	44.173	44.016	2.874	2.520	2.520	49.600	2.5
R8-46E3	52.640	42.05	46.535	46.378	2.874	2.520	2.520	52.000	2.5
R8-49E3	65.040	44.80	49.291	49.134	2.874	2.520	2.520	54.000	2.5
R8-52E3	58.800	47.56	52.047	51.890	2.874	2.520	2.520	58.000	2
R9-55E3	62.300	49.84	55.197	55.139	3.150	2.795	2.795	61.500	2
R9-59E3	66.300	53.78	59.134	58.976	3.150	2.795	2.795	65.500	2
R9-63E3	70.629	57.72	63.071	62.913	3.150	2.795	2.795	69.714	1.75
R9-67E3	75.200	61.65	67.008	66.850	3.150	2.795	2.795	74.286	1.75
R11-71E3	80.342	64.13	70.945	70.787	3.858	3.504	3.504	79.429	1.75
R11-75E3	83.771	68.07	74.882	74.724	3.858	3.504	3.504	82.857	1.75
R11-79E3	87.771	72.00	78.819	78.661	3.858	3.504	3.504	86.857	1.75

## Internal Gears

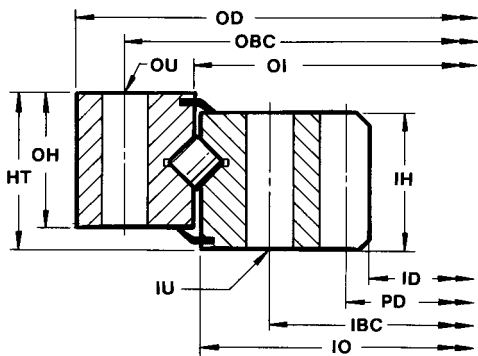

Outline Dimensions (inches)

Model	OD	ID	OI	IO	HT	OH	IH	PD	DP
R8-30N3	34.09	25.100	30.157	30.000	2.874	2.520	2.520	25.500	4
R8-35N3	38.90	29.467	34.961	34.803	2.874	2.520	2.520	30.000	3
R8-39N3	42.60	33.313	38.661	38.504	2.874	2.520	2.520	33.667	3
R8-42N3	46.72	36.560	42.480	42.323	2.874	2.520	2.520	37.200	2.5
R8-44N3	45.50	38.160	44.173	44.016	2.874	2.520	2.520	38.800	2.5
R8-46N3	50.87	40.160	46.535	46.378	2.874	2.520	2.520	40.800	2.5
R8-49N3	53.62	43.360	49.291	49.134	2.874	2.520	2.520	44.000	2.5
R8-52N3	56.38	45.200	52.047	51.890	2.874	2.520	2.520	46.000	2
R9-55N3	60.39	47.700	55.197	55.039	3.150	2.795	2.795	48.500	2
R9-59N3	64.33	51.700	59.134	58.976	3.150	2.795	2.795	52.500	2
R9-63N3	68.27	55.086	63.071	62.913	3.150	2.795	2.795	56.000	1.75
R9-67N3	72.20	59.086	67.008	66.850	3.150	2.795	2.795	60.000	1.75
R11-71N3	77.60	61.371	70.945	70.787	3.858	3.504	3.504	62.286	1.75
R11-75N3	81.54	65.371	74.882	74.724	3.858	3.504	3.504	66.266	1.75
R11-79N3	85.47	69.943	78.819	78.661	3.858	3.504	3.504	70.857	1.75

Gear Data					Mounting Holes						Nominal Capacity		
Tooth Form (20°)	Gear Hardness (BHN)	F	No. of Teeth	Max. Allow. Tang. Tooth Load (lbs)	OBC	OU	No. of Holes OBC	IBC	IU	No. of Holes IBC	Compressive Thrust (lbs)	Moment (ft-lbs)	Wt. (lbs)
Stub	250-300	2.520	139	11,309	32.625	.69	24	27.500	.69	24	373,200	228,700	280
Stub	250-300	2.520	120	14,900	37.500	.69	30	32.250	.69	30	431,700	309,800	339
Stub	250-300	2.520	130	15,000	41.125	.69	30	36.000	.69	30	476,600	369,500	363
Stub	250-300	2.520	119	17,800	45.000	.69	36	39.875	.69	36	526,100	459,100	421
Stub	250-300	2.520	124	17,900	46.750	.81	36	41.375	.81	36	553,000	501,600	460
Stub	250-300	2.520	130	18,000	49.125	.81	36	43.750	.81	36	580,000	552,400	487
Stub	250-300	2.520	136	18,100	51.875	.81	40	46.500	.81	40	618,300	617,400	511
Stub	250-300	2.520	116	22,200	54.625	.81	42	49.250	.81	42	656,500	685,900	584
Stub	250-300	2.795	123	24,800	58.375	1.06	36	51.875	1.06	36	741,900	829,800	776
Stub	250-300	2.795	131	24,900	62.250	1.06	40	55.875	1.06	40	794,300	946,300	857
Stub	250-300	2.795	122	28,300	66.250	1.06	40	59.750	1.06	40	836,300	1,099,000	903
Stub	250-300	2.795	130	28,500	70.125	1.06	44	63.750	1.06	44	894,800	1,217,000	1003
Stub	250-300	3.504	139	36,000	75.000	1.31	36	66.750	1.31	36	1,207,300	1,733,300	1580
Stub	250-300	3.504	145	36,200	79.000	1.31	36	70.625	1.31	36	1,290,400	1,954,600	1664
Stub	250-300	3.504	152	36,300	82.875	1.31	40	74.625	1.31	40	1,348,900	2,109,400	1732

Gear Data					Mounting Holes						Nominal Capacity		
Tooth Form (20°)	Gear Hardness (BHN)	F	No. of Teeth	Max. Allow. Tang. Tooth Load (lbs)	OBC	OU	No. of Holes OBC	IBC	IU	No. of Holes IBC	Compressive Thrust (lbs)	Moment (ft-lbs)	Wt. (lbs)
Stub	250-300	2.520	102	12,600	32.625	.69	24	27.500	.69	24	373,200	228,700	273
Stub	250-300	2.520	90	16,600	37.500	.69	30	32.250	.69	30	431,700	309,800	324
Stub	250-300	2.520	101	16,800	41.125	.69	30	36.000	.69	30	476,600	369,500	361
Stub	250-300	2.520	93	20,100	45.000	.69	36	39.875	.69	36	526,100	459,100	416
Stub	250-300	2.520	97	20,200	46.750	.81	36	41.375	.81	36	553,000	501,600	451
Stub	250-300	2.520	102	20,200	49.125	.81	36	43.750	.81	36	580,000	552,400	478
Stub	250-300	2.520	110	20,400	51.875	.81	40	46.500	.81	40	618,300	617,400	507
Stub	250-300	2.520	92	25,100	54.625	.81	42	49.250	.81	42	656,500	685,900	566
Stub	250-300	2.795	97	28,100	58.375	1.06	36	51.875	1.06	36	741,900	829,800	769
Stub	250-300	2.795	105	28,000	62.250	1.06	40	55.875	1.06	40	794,300	946,300	802
Stub	250-300	2.795	96	31,900	66.250	1.06	40	59.750	1.06	40	836,300	1,099,000	910
Stub	250-300	2.795	105	32,000	70.125	1.06	44	63.750	1.06	44	894,800	1,217,000	930
Stub	250-300	3.504	109	40,400	75.000	1.31	36	66.750	1.31	36	1,207,300	1,733,300	1556
Stub	250-300	3.504	116	40,600	79.000	1.31	36	70.625	1.31	36	1,290,400	1,954,600	1660
Stub	250-300	3.504	124	40,700	82.875	1.31	40	74.625	1.31	40	1,348,900	2,109,400	1693

Nominal Capacity ratings are non-simultaneous raceway maximums (RWSF=1.00 for any one load).

Nominal Moment Capacity ratings may be limited by bolts.

Load Capacity charts are valid for combined Axial and Moment loads only; they should not be used when radial loads exceed 10% of the axial load.

Load Capacity Chart moment capacities may be limited by bolt load capacities.

Nominal capacity ratings are non-simultaneous maximums at raceway service factor = 1.00. Refer to the capacity curves for combined loading. Catalog illustrations are approximate. Seals, bolt spacing and other details may vary.

Contact the Rotek Application Engineering Department for current drawings prior to doing significant layout and design.

Rotek recommends consulting pages 12 - 36 for additional information that must be reviewed prior to slewing ring selection.

Numerous larger, smaller and intermediate sized standard models are available that are not cataloged here. Call your local Rotek Sales Engineer or the Rotek Application Engineering Department at 800/221-8043 for information on non-cataloged models.

Note: Many Gears are modified. Request drawing from Rotek.



# Series 6000 High-Speed Radial Ball Slewing Rings

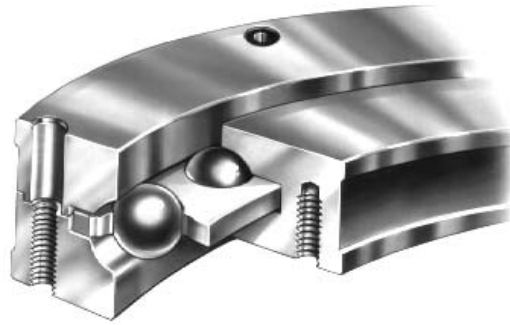

Rotek Series 6000 slewing rings are single row, high-speed ball slewing rings capable of raceway velocities of up to 3,000 feet per minute with proper lubrication.

These slewing rings feature exceptionally durable radial cages and are capable of sustained high-speed operation. Series 6000 slewing rings are often selected based on dynamic capacity limitations which impose more severe limits on loads than static capacity.

## Available In Many Models

Here is a summary of the range of specifications that can be accommodated with Rotek Series 6000 slewing rings:

### Slewing Ring Diameters:

Domestic models from 12" to 180" O.D.

### Maximum Raceway Velocity:

up to 3,000 feet per minute  
(Oil lubrication recommended over 1,000 fpm)

### Maximum Loads:

(Standard Models)

Thrust loads to 1,000,000 pounds  
Moment loads to 2,500,000 foot-pounds  
Radial loads to 244,000 pounds

☎ Contact Rotek for load information on special order models.

### Tolerances:

Available in standard or precision grades

### Gearing:

Gearless models most common

## Ideal For High-Speed Applications

Series 6000 slewing rings have been used extensively in equipment that requires high-speed rotation capabilities. Typical applications include:

- Log-debarking machines
- Coil windows
- Payoff reels
- High-speed capstans

## Capacity Curves

The raceway capacity charts at right can be used to select a Series 6000 model for specific application loads.

To use the charts, first calculate the net thrust and moment loads for the application. Next, multiple these figures by the appropriate recommended minimum service factor, (see page 19). Then plot the corrected thrust and moment loads on the appropriate chart. From the point where the plot lines intersect, select the slewing ring whose capacity is at, above, or to the right of the intersection point.

Bolt capacities may limit the raceway moment capacities shown.

☎ Contact Rotek for dynamic capacities.

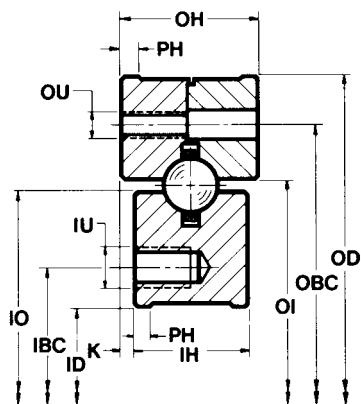

Nominal capacity ratings are non-simultaneous maximums at raceway service factor = 1.00. Refer to the capacity curves for combined loading. Catalog illustrations are approximate. Seals, bolt spacing and other details may vary. Contact the Rotek Application Engineering Department for current drawings prior to doing significant layout and design.

Rotek recommends consulting pages 12 - 36 for additional information that must be reviewed prior to slewing ring selection.

Numerous larger, smaller and intermediate sized standard models are available that are not cataloged here. Call your local Rotek Sales Engineer or the Rotek Application Engineering Department at 800/221-8043 for information on non-cataloged models.

Model No.	Outline Dimensions (inches)								Mounting Holes						Static Radial Capacity (lbs)	Weight (lbs)
	OD	ID	OI	IO	OH	IH	K	PH	OBC	OU	No. Of Holes OBC	IBC	IU	No. Of Holes IBC		
W13-24P1	31.890	21.654	27.09	26.46	3.55	2.77	.39	.59	30.510	5/8-11	12	23.23	5/8-11	12	53,570	368
W13-35P1	40.555	29.525	35.36	34.72	3.74	2.96	.39	.59	38.785	5/8-11	16	—	—	—	66,960	510
W13-38P1	43.310	32.280	38.11	37.48	3.74	2.96	.39	.59	41.540	5/8-11	16	34.25	5/8-11	16	80,350	564
W13-43P2	48.429	37.399	43.23	42.60	3.74	2.96	.39	.59	46.659	5/8-11	16	—	—	—	88,380	629
W13-49P1	55.120	43.310	49.53	48.90	3.94	3.16	.39	.59	52.950	5/8-11	24	45.47	5/8-11	24	96,420	807
W13-51P1D	57.085	45.275	51.50	50.86	3.94	3.16	.39	.59	54.915	5/8-11	24	—	—	—	104,450	860
W14-60P1	66.530	53.150	60.24	59.45	4.33	3.55	.39	.59	63.980	5/8-10	24	56.10	3/4-10	24	127,750	1270
W14-71P1	78.740	63.780	71.65	70.87	4.72	3.94	.39	.59	75.390	5/8-10	24	67.32	3/4-10	24	166,080	1911
W16-84P1	91.340	75.590	84.25	83.45	5.11	4.33	.39	.59	88.580	1 - 8	30	79.53	1 - 8	30	204,420	2504
W17-108P1	116.930	99.210	108.74	107.80	5.51	4.33	.59	.59	113.190	1 - 8	30	103.54	1 - 8	30	244,240	3740

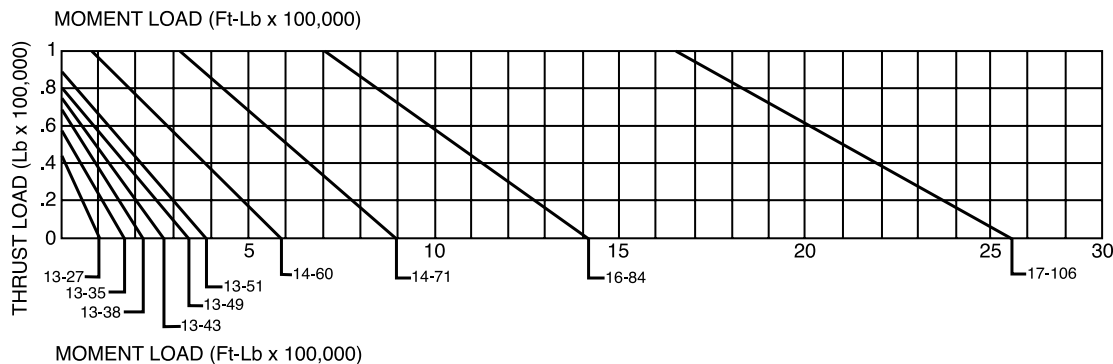
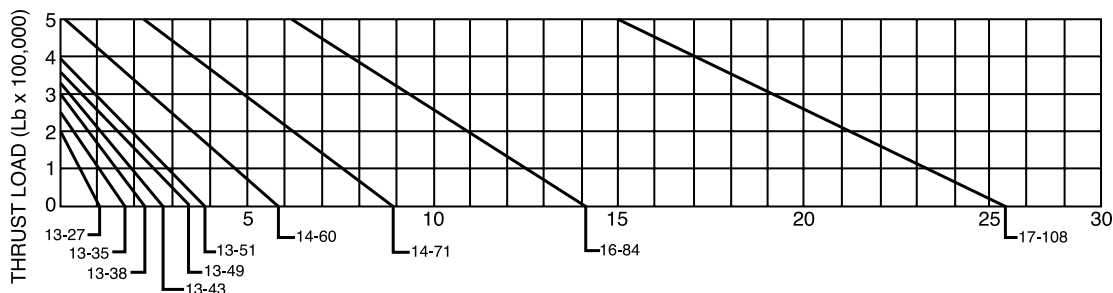

## Series 7100 and 8000 Single Row Vertical Thrust Slewing Rings

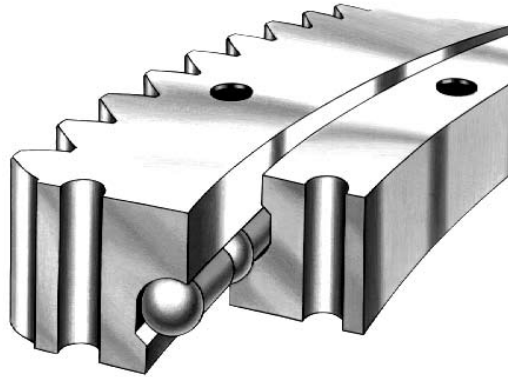

Series 7100

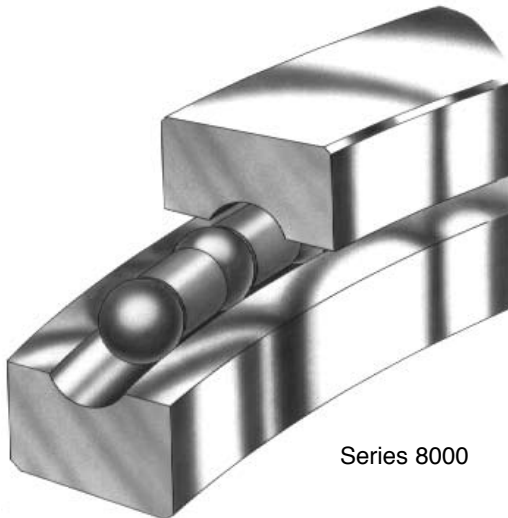

Series 8000

Series 7100 and Series 8000 slewing rings are single row ball slewing rings designed for applications where the center of force remains within the slewing ring diameter under normal operating conditions. Thrust is transmitted at a 90° contact angle, making the most efficient use of the slewing ring capacity.

Series 7100 slewing rings include lift-off protection to hold the assembly together under occasional uplifting loads.

Series 8000 slewing rings are furnished as rings, raceways, balls and separators only. No mounting holes or gearing are available on this style slewing ring. They offer the lowest cost per unit diameter for heavy pure thrust loads.

### Available In Many Models

Here is a summary of the range of specifications that can be accommodated with Rotek Series 7100 and Series 8000 slewing rings:

#### Slewing Ring Diameters:

Domestic models from 12" to 180" O.D.

#### Maximum Raceway Velocity:

700 feet per minute

#### Maximum Loads:

Thrust loads to 1,290,000 pounds

Series 7100 and Series 8000 slewing rings are not intended or recommended for moment or radial loading.

#### Tolerances:

Available in standard grades only.

#### Gearing:

Series 7100: Internal and external gearing, or gearless

Series 8000: Available in gearless models only

### Ideal For Heavy Pure Thrust Loads

Series 7100 and Series 8000 slewing rings have been used extensively in applications where the center of force remains within the slewing ring diameter under normal operating conditions.

Typical applications include:

- Large turntables
- Sewage and water treatment equipment
- Clarifiers
- Thickeners
- Rotary distributors

# Series 7100 Dimensions and Capacities

Outline Dimensions (inches)

Model No.	OD	ID	OI	IO	HT	OH	IH
S8-50E1	54.867	46.50	49.56	50.44	2.88	2.62	2.25
S8-56E1	60.867	52.50	55.56	56.44	2.88	2.62	2.25
S10-63E1	67.867	58.38	61.95	63.05	3.19	2.88	2.56
S12-70E1	76.240	65.38	69.34	70.66	3.44	3.12	2.81
S14-80E1	86.640	74.62	79.11	80.64	4.38	4.00	3.38
S14-90E1	96.640	84.62	89.11	90.64	4.38	4.00	3.38
S16-100E1	107.800	94.00	99.12	100.88	4.62	4.25	3.62
S16-112E1	119.800	106.00	111.12	112.88	4.62	4.25	3.62
S20-125E1	134.057	117.88	123.90	126.10	5.44	5.00	4.44
S22-140E1	149.733	132.75	138.79	141.21	5.75	5.25	4.75
S24-158E1	168.480	149.50	156.48	158.82	6.00	5.50	5.00
S24-178E1	189.280	168.00	176.18	178.82	6.00	5.50	5.00

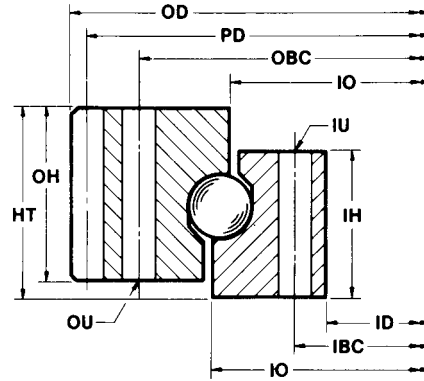

Gear Data							Mounting Holes					Wt. (lbs)	Thrust Capacity (lbs)	
Model No.	PD	DP	Tooth Form (20°)	Gear Hardness (BHN)	No. Of Teeth	Max. Allow. Tang. Tooth Load (lbs)	OBC	OU	No. of Holes OBC	IBC	IU			No. of Holes IBC
S8-50E1	54.333	3	STUB	250-300	163	15,820	52,5000	.56	24	47.500	.56	24	417	235,000
S8-56E1	60.333	3	STUB	250-300	181	15,960	58.500	.56	24	53.500	.56	24	469	262,000
S10-63E1	67.333	3	STUB	250-300	202	17,640	65.500	.69	24	59.500	.69	24	629	321,000
S12-70E1	75.600	2.5	STUB	250-300	189	22,820	73.250	.81	24	66.750	.81	24	906	387,000
S14-80E1	86.000	2.5	STUB	250-300	215	29,400	83.500	.94	24	76.250	.94	24	1440	469,000
S14-90E1	96.000	2.5	STUB	250-300	240	29,540	93.500	.94	24	86.250	.94	24	1624	529,000
S16-100E1	107.000	2	STUB	250-300	214	39,060	104.000	1.06	24	96.000	1.06	24	2193	620,000
S16-112E1	119.000	2	STUB	250-300	238	39,200	116.000	1.06	24	108.000	1.06	24	2444	693,000
S20-125E1	133.143	1.75	STUB	250-300	233	52,780	129.500	1.19	24	120.000	1.19	24	3805	847,000
S22-140E1	148.667	1.50	STUB	250-300	223	65,900	145.000	1.19	24	135.000	1.19	24	4769	989,000
S24-158E1	167.200	1.25	STUB	250-300	209	80,780	163.000	1.19	24	152.000	1.19	24	6195	1,150,000
S24-178E1	188.000	1.25	STUB	250-300	235	81,340	183.000	1.19	24	171.000	1.19	24	7894	1,290,000

Nominal capacity ratings are non-simultaneous maximums at raceway service factor = 1.00. Refer to the capacity curves for combined loading. Catalog illustrations are approximate. Seals, bolt spacing and other details may vary. Contact the Rotek Application Engineering Department for current drawings prior to doing significant layout and design.

Rotek recommends consulting pages 12 - 36 for additional information that must be reviewed prior to slewing ring selection.

Numerous larger, smaller and intermediate sized standard models are available that are not cataloged here. Call your local Rotek Sales Engineer or the Rotek Application Engineering Department at 800/221-8043 for information on non-cataloged models.

# Series 10,000 Heavy Duty Slewing Rings

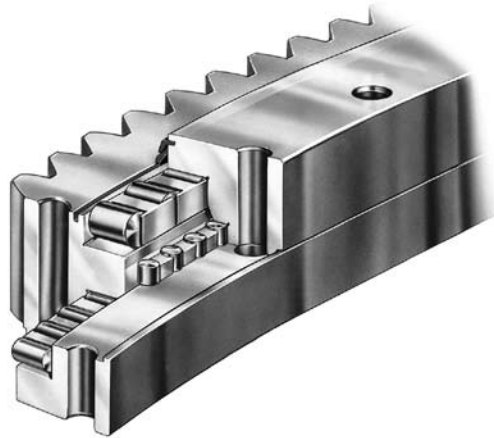

Rotek Series 10,000 heavy duty slewing rings offer more load capacity per unit size than any other Rotek design. Series 10,000 slewing rings are constructed with three independent rows of rollers. Rollers are separated by either steel cages or plastic spacers, depending on application requirements.

Since all loading is transmitted directly to raceway surfaces that are perpendicular to the load direction, the capacity of each rolling element is utilized in the most efficient manner possible.

The perpendicular arrangement of the rolling elements also minimizes the amount of axial deflection that occurs between the slewing ring rings when under load, making the Series 10,000 inherently the stiffest slewing ring available from Rotek. In addition, frictional torque is lower than other styles of Rotek slewing rings under most load conditions.

Because of their high-load carrying capability, Series 10,000 slewing rings must be mounted on a companion structure which is sufficiently uniform in stiffness to properly distribute the loading around the slewing ring. (See page 29 for information on companion structure requirements.) Special consideration must also be given to the number of mounting holes and bolts that will be required to safely transmit the maximum rated moment load. In some models, mounting holes in addition to standard specifications may be required.

## Available in Many Models

Here is a summary of the range of specifications that can be accommodated in Series 10,000 models:

### Raceway Diameters:

- Standard models from 12" to 180"
- Special order slewing rings up to 360"

### Maximum Raceway Velocity:

700 feet per minute

### Maximum Loads:

(Standard models)

- Thrust loads to 23,000,000 pounds
- Moment loads to 61,000,000 foot-pounds
- Radial loads to 2,500,000 pounds

☎ Contact Rotek for load information on special order models.

### Tolerances:

Available in standard or precision grades

## Ideal for Demanding Applications

Series 10,000 slewing rings have demonstrated excellent durability in a variety of applications where extremely heavy loads are involved. Typical applications include:

- Heavy Duty Cranes, including off-shore, ship-board, dockside and crawler crane applications
- Excavators
- Stackers/Reclaimers
- Tunnel-boring Machines
- Precision radar antenna pedestals
- Ladle Turrets
- Mooring Buoys

# Series 10,000 Load Capacities of Selected Models

## Capacity Curves

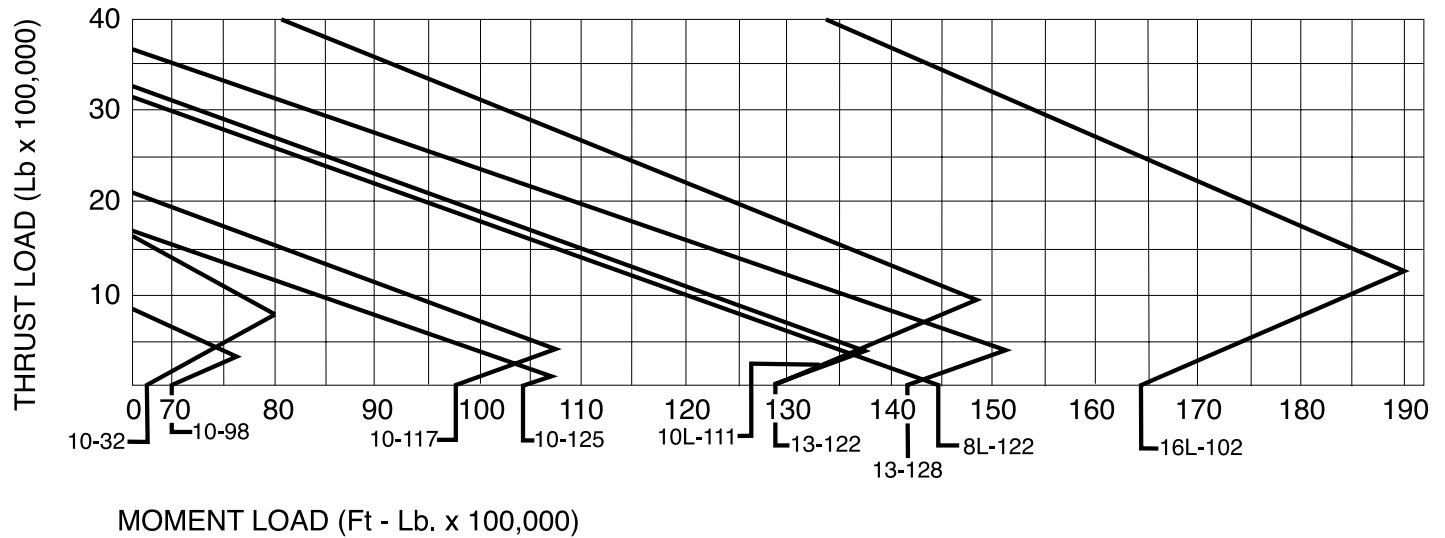
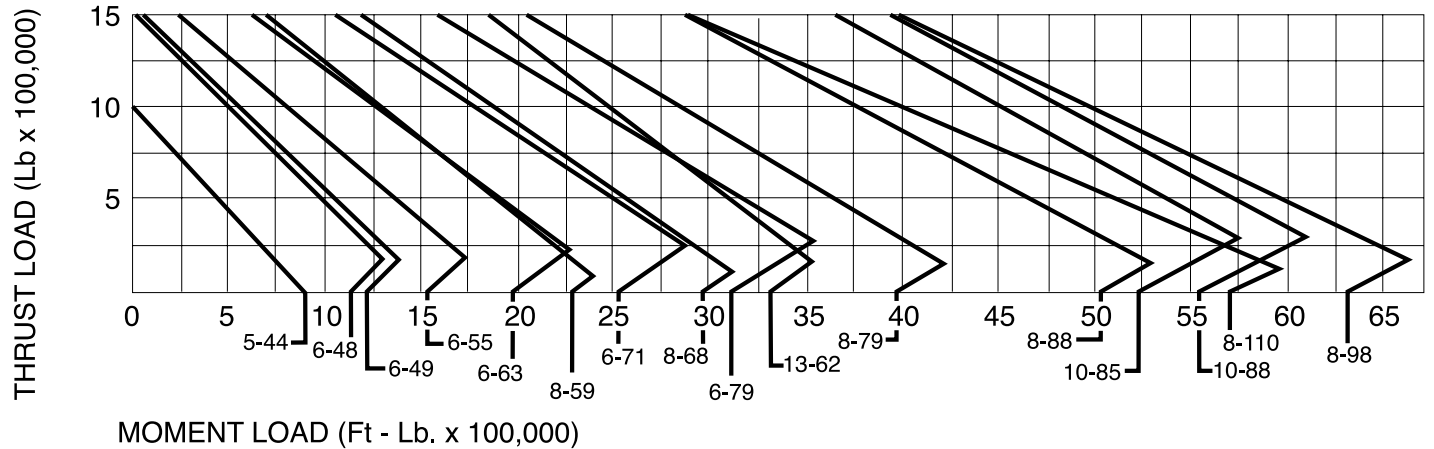

The capacity charts above can be used to select a Series 10,000 model for specific application loads.

To use the charts, first calculate the net thrust and moment loads for the application. Next, multiply these figures by the appropriate recommended minimum service factor (see page 19). Then plot the corrected thrust and moment loads on the appropriate chart. From the point where the plot lines intersect, select the slewing ring whose capacity is at, above, or to the right of the intersection point.

For models not shown on the charts, consult the dimensional tables for maximum nominal thrust and moment capacities (page 72.) Contact Rotek for any additional information on these models.

# Series 10,000 Dimensional Information

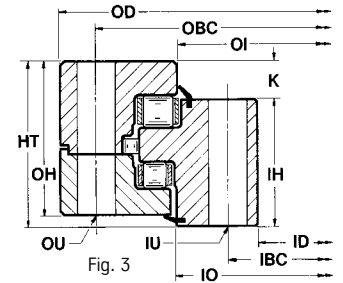
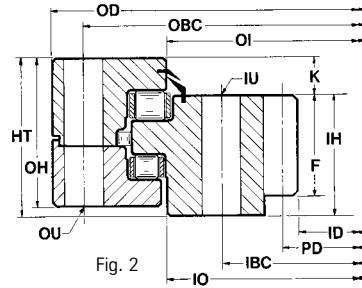
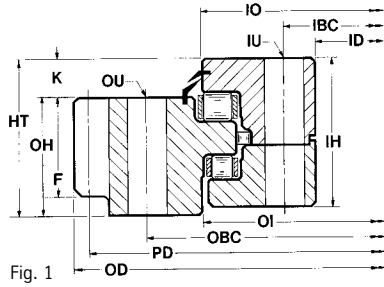

External Gears		Outline Dimensions (inches)							Gear Data				
Model Number	HT	OH	K	IH	OD	OI	IO	ID	PD	DP	Tooth Form (20°)	Gear Hardness (BHN)	
3R6-48E3B	5.00	4.50	.50	4.50	57.100	48.86	49.09	42.50	56.000	1.5	F.D.	250-300	
3R6-49E9	4.72	3.70	1.02	4.41	57.040	50.04	50.28	43.90	56.400	2.5	STUB	250-300	
3R6-55E9	4.72	3.70	1.02	4.41	63.300	55.94	56.18	49.80	62.500	2.0	STUB	250-300	
3R6-63E9	4.72	3.70	1.02	4.41	70.800	63.82	64.05	57.68	70.000	2.0	STUB	250-300	
3R6-71E9	4.72	3.70	1.02	4.41	79.200	71.69	71.93	65.55	78.286	1.75	STUB	250-300	
3R6-79E9	4.72	3.70	1.02	4.41	87.200	79.57	79.80	73.43	86.286	1.75	STUB	250-300	
3R8-79E9	5.79	4.49	1.30	5.43	88.343	79.76	80.04	72.05	87.429	1.75	STUB	250-300	
3R8-88E9	5.79	4.49	1.30	5.43	98.400	89.21	89.49	81.50	97.333	1.5	STUB	250-300	
3R8-98E9	5.79	4.49	1.30	5.43	108.400	99.45	99.72	91.73	107.333	1.5	STUB	250-300	
3R10-82E3C	9.12	7.62	1.50	7.75	94.742	83.46	84.57	72.25	94.000	2.0	STUB	250-300	
3R16-197E2	10.55	7.99	2.56	10.16	213.354	198.66	199.21	186.42	209.764	24 Module	F.D.	250-300	
3R16-220E1	10.55	7.99	2.56	10.16	236.976	222.28	222.83	210.04	234.331	24 Module	F.D.	250-300	
3R16-248E1	10.55	7.99	2.56	10.16	264.378	249.84	250.39	237.60	260.787	24 Module	F.D.	250-300	
3R16-265E1	10.55	7.99	2.56	10.16	281.386	266.97	267.52	254.72	287.740	24 Module	F.D.	250-300	
<b>Internal Gears</b>													
3R6-49N9	4.72	4.41	1.02	3.70	54.53	48.15	48.39	41.760	42.400	2.5	STUB	250-300	
3R6-55N9	4.72	4.41	1.02	3.70	60.43	54.06	54.29	47.200	48.000	2.0	STUB	250-300	
3R6-63N9	4.72	4.41	1.02	3.70	68.31	61.93	62.17	54.700	55.500	2.0	STUB	250-300	
3R6-71N9	4.72	4.41	1.02	3.70	76.18	69.80	70.04	62.514	63.429	1.75	STUB	250-300	
3R6-79N9	4.72	4.41	1.02	3.70	84.05	77.68	77.91	70.514	71.429	1.75	STUB	250-300	
3R8-59N2C	5.75	5.08	1.00	4.75	66.50	58.07	58.39	50.700	51.500	2.0	STUB	250-300	
3R8-59N2E	5.75	5.06	1.00	4.75	66.50	58.07	58.39	50.700	51.500	2.0	STUB	250-300	
3R8-68N3B	5.62	5.43	.62	5.00	74.50	66.50	66.57	58.796	59.333	1.5	F.D.	250-300	
3R8-79N9	5.79	5.43	1.30	4.49	85.43	77.44	77.72	69.372	70.286	1.75	STUB	250-300	
3R8-88N9	5.79	5.43	1.30	4.49	94.88	86.89	87.17	78.267	79.333	1.5	STUB	250-300	
3R8-98N1	5.43	5.08	1.30	4.13	105.12	97.13	97.44	87.165	87.165	18 Module	F.D.	250-300	
3R8-98N9	5.79	5.43	1.30	4.49	105.12	97.13	97.40	88.267	89.333	1.5	STUB	250-300	
3R8-110N1	5.50	5.12	1.25	4.25	117.25	108.94	109.25	99.600	100.667	1.5	STUB	250-300	
3R8-122N1A	7.75	7.38	.63	7.12	130.25	119.69	119.45	109.600	110.667	1.5	STUB	250-300	
3R10-85N2A	7.50	6.88	.44	7.06	92.75	83.62	84.06	72.164	73.000	1.0	F.D.	250-300	
3R10-88N2B	7.00	6.88	1.50	5.50	96.00	86.29	86.73	75.200	76.800	1.25	F.D.	270-320	
3R10-98N1B	8.88	8.50	1.32	7.56	107.00	97.50	96.68	87.165	87.874	18 Module	F.D.	250-300	
3R10-111N2F	8.75	8.12	.63	8.12	119.50	104.00	109.61	98.400	100.000	1.25	F.D.	250-300	
3R10-117N3D	8.38	6.81	1.50	6.88	125.62	115.20	115.63	106.333	107.333	1.5	SPEC.	250-300	
3R13-62N1E	8.62	8.12	1.87	6.75	70.50	59.80	60.31	50.200	51.000	2.0	STUB	250-300	
3R13-122N1B	9.00	8.50	1.00	8.00	131.25	120.08	120.59	109.600	110.667	1.5	STUB	285-321	
3R13-128N1A	12.32	8.27	1.89	10.43	136.73	126.18	126.81	115.400	117.000	1.0	STUB	285-321	
3R16-197N1	10.55	10.18	2.56	7.99	207.28	194.49	195.04	180.472	181.417	24 Module	F.D.	250-300	
3R16-220N1	10.55	10.18	2.56	7.99	230.91	218.11	218.66	204.094	205.039	24 Module	F.D.	250-300	
3R16-245N1	10.55	10.16	2.56	7.99	258.46	245.67	246.220	231.496	232.441	24 Module	F.D.	250-300	
3R16-265N3	10.55	10.16	2.56	7.99	279.59	262.80	263.346	248.504	249.449	24 Module	F.D.	250-300	
<b>Gearless</b>													
3R5-44P2A	4.00	3.25	.37	4.00	49.50	44.37	44.53	38.00	-	-	-	-	
3R6-49P9	4.72	4.41	1.02	3.70	54.53	48.15	48.39	43.50	-	-	-	-	
3R6-55P9	4.72	4.41	1.02	3.70	60.43	54.06	54.29	49.41	-	-	-	-	
3R6-63P9	4.72	4.41	1.02	3.70	68.31	61.93	62.17	57.28	-	-	-	-	
3R6-71P9	4.72	4.41	1.02	3.70	76.18	69.80	70.04	65.16	-	-	-	-	
3R6-79P9	4.72	4.41	1.02	3.70	84.05	77.68	77.91	73.03	-	-	-	-	
3R8-79P9	5.79	5.43	1.30	4.49	85.43	77.44	77.72	71.65	-	-	-	-	
3R8-88P9	5.79	5.43	1.30	4.49	94.88	86.89	87.17	81.10	-	-	-	-	
3R8-98P9	5.79	5.43	1.30	4.49	105.12	97.13	97.40	91.34	-	-	-	-	
3R10-98P9	7.13	6.77	1/65	5.47	105.91	96.81	97.24	89.96	-	-	-	-	
3R10-125P1B	7.24	5.59	.47	6.77	133.94	126.22	127.32	116.54	-	-	-	-	
3R16-102P5	14.12	11.75	2.00	12.12	116.75	105.04	106.38	89.38	-	-	-	-	

F.D.: Full Depth.

Spec.: Special form.

# Series 10,000 Dimensional Information

Nominal capacity ratings are non-simultaneous maximums at raceway service factor = 1.00. Refer to the capacity curves for combined loading. Catalog illustrations are approximate. Seals, bolt spacing and other details may vary. Contact the Rotek Application Engineering Department for current drawings prior to doing significant layout and design.

Rotek recommends consulting pages 12 - 36 for additional information that must be reviewed prior to slewing ring selection. Numerous larger, smaller and intermediate sized standard models are available that are not cataloged here. Call your local Rotek Sales Engineer or the Rotek Application Engineering Department at 800/221-8043 for information on non-cataloged models.

External Gears			Mounting Holes						Nominal Capacity				
F	No. Of Teeth	Max. Allow Tang. Tooth Load (lbs)	OBC	OU	No. Of Holes		IU	No. Of Holes IBC	Curve No.	Radial (lbs)	Compressive Thrust (lbs)	Moment (ft-lbs)	Wt. (lbs)
4.00	84	40,695	52.000	1.09	40	44.375	1.09	40	6-48	129,000	1,523,000	1,151,000	1129
3.39	141	24,423	53.346	1.02	36	45.472	1.02	36	6-49	172,000	1,563,000	1,218,000	917
3.39	125	30,179	59.251	1.02	36	51.378	1.02	36	6-55	194,000	1,751,000	1,527,000	1091
3.39	140	30,293	67.126	1.02	40	59.252	1.02	40	6-63	222,000	2,002,000	1,994,000	1215
3.39	137	34,820	75.000	1.02	46	67.126	1.02	46	6-71	250,000	2,254,000	2,525,000	1426
3.39	151	35,166	82.874	1.02	54	75.000	1.02	54	6-79	279,000	2,505,000	3,118,000	1556
4.13	153	42,901	83.661	1.30	44	74.212	1.30	44	8-79	376,000	2,779,000	3,997,000	2284
4.13	146	49,764	93.110	1.30	48	83.661	1.30	48	8-88	422,000	3,112,000	5,018,000	2657
4.13	161	50,355	103.346	1.30	54	93.897	1.30	54	8-98	472,000	3,473,000	6,255,000	2914
5.50	188	48,741	89.750	1.62	60	75.250	1.62	70	10-82	449,000	5,581,000	6,776,000	5291
7.99	222	190,458	204.724	1.77	78	189.960	1.77	78	**	1,440,000	13,100,000	44,400,000	18,208
7.99	248	190,458	228.346	1.77	90	213.583	1.77	90	**	1,620,000	14,800,000	58,800,000	20,830
7.99	276	190,456	255.906	1.77	100	241.142	1.77	100	**	1,848,000	16,750,000	72,200,000	23,228
7.99	295	190,456	273.032	1.77	108	258.268	1.77	108	**	1,950,000	17,980,000	82,600,000	24,692
<b>Internal Gears</b>													
3.39	106	27,172	52.953	1.02	36	45.079	1.02	36	6-49	182,000	1,563,000	1,218,000	893
3.39	96	33,708	58.858	1.02	36	50.984	1.02	36	6-55	203,000	1,751,000	1,527,000	1032
3.39	111	34,116	66.732	1.02	40	58.858	1.02	40	6-63	231,000	2,002,000	1,994,000	1206
3.39	111	38,998	74.606	1.02	46	66.732	1.02	46	6-71	260,000	2,254,000	2,525,000	1391
3.39	125	39,416	82.480	1.02	54	74.606	1.02	54	6-79	288,000	2,505,000	3,118,000	1559
3.75	103	37,232	63.500	1.31	26*	55.000	1.31	40	8-59	917,000	2,084,000	2,290,000	1725
3.75	103	37,232	63.500	1.31	24*	55.000	1.31	40	8-59	917,000	2,084,000	2,290,000	1725
5.00	89	57,100	72.000	1.19	28	64.125	1.31	48	8-68	340,000	2,380,000	2,978,000	2070
4.13	123	47,940	83.268	1.30	48	73.819	1.30	44	8-79	396,000	2,779,000	3,997,000	2293
4.13	119	55,784	92.716	1.30	48	83.268	1.30	48	8-68	441,000	3,112,000	5,018,000	2597
4.13	124	50,200	102.953	1.31	66	93.504	1.31	66	8-98	383,000	3,470,000	6,304,000	2917
4.13	134	56,451	102.953	1.30	54	93.504	1.30	54	8-98	489,000	2,798,000	5,700,000	2928
4.25	151	58,764	114.750	1.31	72	105.312	1.31	72	8-110	437,000	3,470,000	6,304,000	3336
6.50	166	93,900	127.250	1.59	60	115.500	1.59	60	8L-122	708,000	5,858,000	14,485,000	6810
6.26	73	107,300	90.250	1.31	44	79.250	1.31	44	10-85	428,000	3,606,000	5,238,000	4310
5.00	96	73,800	93.125	1.59	48*	81.750	1.59	40	10-88	545,000	3,708,000	5,570,000	4014
7.56	124	91,900	102.953	1.62	66	93.504	1.62	66	10-98	489,000	4,153,000	6,896,000	5654
6.00	125	82,300	117.000	1.56	53	105.000	1.56	72	10L-111	444,000	7,568,000	12,861,000	6862
6.88	161	78,600	122.812	1.56	48	112.250	1-1/2-6	72	10-117	727,000	4,943,000	9,780,000	5782
5.00	102	50,300	67.625	1.56	25*	55.000	1.56	40	13-62	441,000	3,000,000	3,340,000	3595
6.50	166	102,000	128.250	1.56	60	115.500	1.56	60	13-122	727,000	5,926,000	12,848,000	8780
10.00	117	234,000	133.661	1.56	108	124.252	M42	90	13-128	678,000	6,211,000	14,177,000	9000
7.99	192	190,458	203.740	1.77	78	188.976	1.77	78	**	1,440,000	13,100,000	44,400,000	18,039
7.99	217	190,458	227.362	1.77	90	212.598	1.77	90	**	1,620,000	14,800,000	58,800,000	20,541
7.99	246	190,458	254.921	1.77	100	240.157	1.77	100	**	1,848,000	16,750,000	72,200,000	23,270
7.99	264	190,458	272.047	1.77	108	257.283	1.77	108	**	1,950,000	17,980,000	82,600,000	24,979
<b>Gearless</b>													
-	-	-	47.500	1.09	16	40.000	1-8	24	5-44	151,000	1,019,000	901,000	776
-	-	-	52.953	1.02	36	45.079	1.02	36	6-49	182,000	1,563,000	1,218,000	805
-	-	-	58.858	1.02	36	50.984	1.02	36	6-55	203,000	1,751,000	1,527,000	908
-	-	-	66.732	1.02	40	58.858	1.02	40	6-63	231,000	2,002,000	1,994,000	1036
-	-	-	74.606	1.02	46	66.732	1.02	46	6-71	260,000	2,254,000	2,525,000	1036
-	-	-	82.480	1.02	54	74.606	1.02	54	6-79	288,000	2,505,000	3,118,000	1290
-	-	-	83.268	1.30	44	73.819	1.30	44	8-79	396,000	2,779,000	3,997,000	2006
-	-	-	92.716	1.30	48	83.268	1.30	48	8-88	441,000	3,112,000	5,018,000	2249
-	-	-	102.953	1.30	54	93.504	1.30	54	8-98	489,000	3,470,000	6,304,000	2509
-	-	-	103.543	1.54	44	92.323	1.54	44	10-98	489,000	2,798,000	6,896,000	3629
-	-	-	131.024	1.38	64	119.606	1.38	64	10-125	763,000	4,330,000	10,428,000	5480
-	-	-	112.625	2.12	48	93.500	2.12	48	16L-102	2,492,000	10,365,000	16,451,000	13,500



## Series 15,000 Wire-Race Heavy Duty Slewing Rings

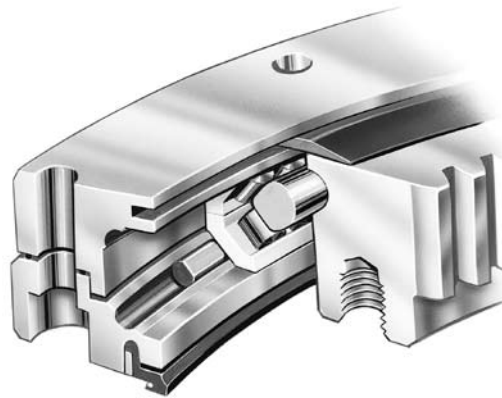

Rotek Series 15,000 Wire-Race slewing rings feature rolling elements that ride on the hardened surfaces of drawn and ground wire-like inserts. The raceway surfaces of these wire races are ground to the profile of the balls or rollers that ride on them. The balance of the insert's cross section is of a circular profile and is fitted into circular grooves machined into the support rings that comprise the slewing ring. The wire-races are not fastened in the grooves, or joined at the ends, but are held in place by the force exerted by the rolling elements.

This construction provides several mechanical advantages over fixed raceway slewing rings:

- The wire-races are free to twist in the grooves, providing a self-aligning capability in situations where the support rings are slightly distorted to conform to mounting structures.
- Because the raceway ends are not joined, the races can migrate in the grooves to accommodate differential expansion.
- Wire-race slewing rings can be pre-loaded for accurate positioning without causing the development of high frictional torque. This ability provides a very stiff rotational system that can be easily driven.
- Wire raceways can be replaced without complete disassembly of the slewing ring.
- Support rings can be manufactured in materials that are more appropriate to a specific application, without sacrificing the integrity of the raceway.

### The solution for a variety of application conditions

Rotek Series 15,000 Wire-Race slewing rings are ideal in applications that challenge conventional slewing ring design. Support rings can be constructed in aluminum alloys to reduce the total weight of the slewing ring, a critical consideration in mobile applications. Support rings can also be supplied in bronze and other materials that resist saltwater and other ambient environments corrosive to steel slewing ring materials.

The ability to “field” replace the wire-race insert and rolling elements also makes the Series 15,000 Wire-Race slewing ring ideal in situations where removal or replacement of an operating slewing ring is difficult or cost prohibitive.

### Available in three configurations

Rotek Series 15,000 Wire-Race slewing rings are custom designed and manufactured, and are available in three different configurations: single-row, four-point contact ball style; two-row roller style; and three-row roller style (see page 75 for additional information). Here is a summary of the range of specifications that can be accommodated by Series 15,000 Wire-Race slewing rings:

Raceway Diameters:  
From 12” to 600”

Max. Raceway Velocity:  
>700 feet per minute

Max. Loads:

- Thrust loads up to 18,000,000 pounds
- Moment loads up to 700,000,000 foot-pounds
- Radial loads up to 2,000,000 pounds



Many large radar antennas at research and National Weather Service installations turn on Rotek Series 15,000 Wire-Race slewing rings.



High-tech luggage scanners for airport security operations rotate on Rotek Series 15,000 Wire-race slewing rings.

## Ideal for demanding applications

Rotek Series 15,000 Wire-Race slewing rings have demonstrated reliable performance capability and long service life in a variety of demanding situations, including industrial and power-generating applications. Two specific applications are presented here for your review.

# Wire-Race Slewing Ring Construction and Configurations

Typical Wire-Race slewing ring construction

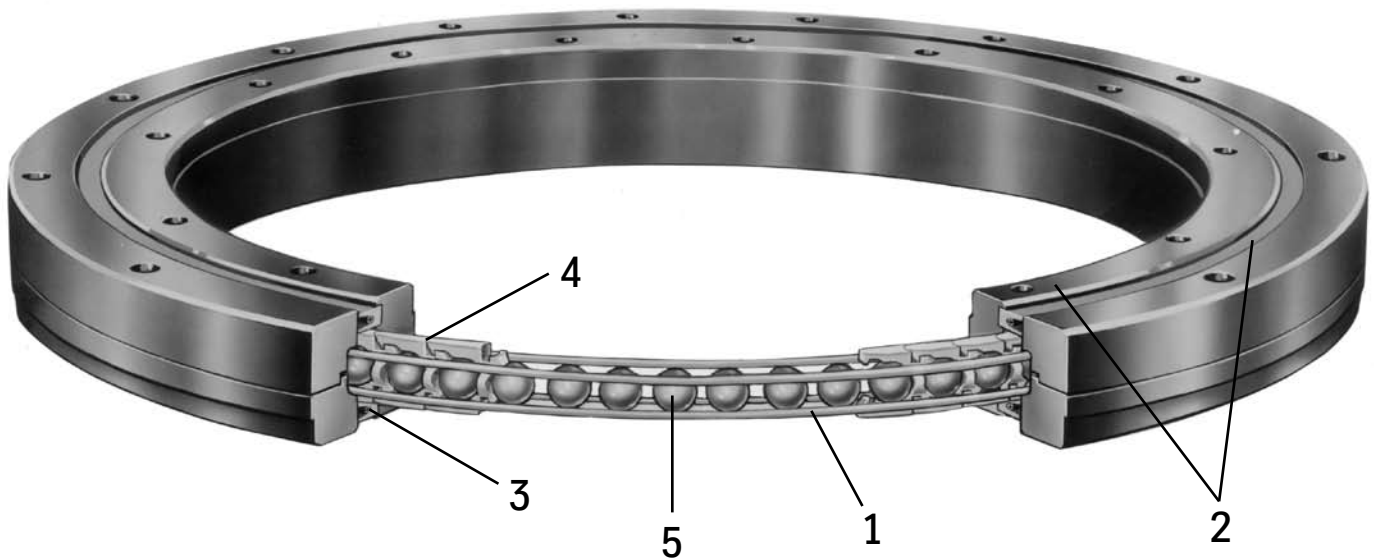

Each configuration incorporates common features designed to provide reliable performance and maximize service life. Referring to the illustration above, these design features include:

**1. Steel raceway inserts**  
Wire-race inserts are manufactured of hardened spring steel or hardened stainless steel (for maximum durability and resistance to corrosion.)

**2. Support rings manufactured in materials appropriate for the application**  
The use of wire-race inserts allows supporting rings to be manufactured in materials that may be more appropriate to a specific application than the steel that machined raceways

require. Series 15,000 Wire-Race slewing rings are available with supporting rings of aluminum to reduce slewing ring weight, bronze for saltwater environments, and a variety of other materials.

**3. Integral Seals**  
Integral seals are usually incorporated in the slewing ring to prevent slewing ring failure through abrasive contamination and leaching away of lubricant.

**4. Polymeric cages for rolling elements**  
Rolling elements, either rollers or balls, are installed with polymeric cages to avoid rolling element-to-rolling element contact and to assure proper spacing.

**5. Rolling elements**  
Rolling elements, ball or rollers, are often manufactured of hardened stainless steel to resist corrosion.

Integral gearing

Series 15,000 Wire-Race slewing rings can be supplied with integral external or internal gearing, or gearless.

# Wire-Race Slewing Ring Construction and Configurations

Available in various design configurations



Rotek Series 15,000 Wire-Race slewing rings are available in many different configurations. Four-point ball type styles are designed to use balls that roll within an x-shaped array of four wire-race inserts. Dual row configurations are also available.

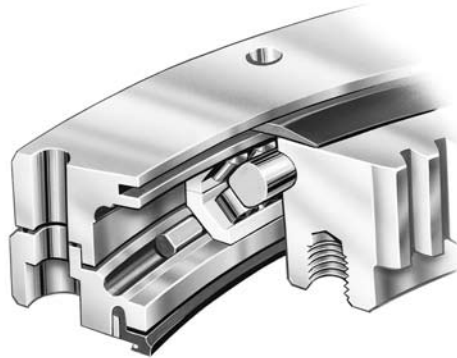

Two-row roller style slewing rings have two rows of rollers that are angled at 45° to the cross section's vertical axis, and roll between raceways formed by a triangular array of wire-race inserts. This style of Wire-Race slewing ring offers greater radial stiffness than the ball type. Double row designs provide more uniform frictional characteristics under both normal (level) and tilting load conditions than a single-row four-point ball type.

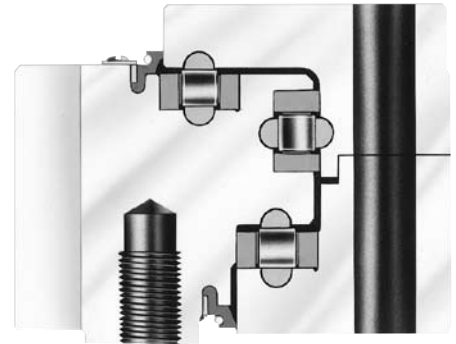

Three-row roller style slewing rings incorporate three rows of rollers, each traveling in its own set of wire-race inserts. One row of rollers is axially (vertically) oriented to carry radial loads. The other two rows are radially (horizontally) oriented to carry thrust and overturning loads. This style of Wire-Race slewing ring is heavier and stiffer than, but not as resilient or accommodating as, the two-row roller style and requires a more carefully designed mounting structure.

## Roller versus ball type slewing rings

Wire-Race slewing rings with rollers as rolling elements offer greater radial stiffness than slewing rings utilizing balls as rolling elements. This characteristic is important in situations where slewing rings under load are subject to sloping, such as mobile applications. The greater radial stiffness of roller slewing rings provides more uniform torque characteristics under the localized loading associated with slopes. The superior radial stiffness of the roller type slewing ring also offers higher resonant frequency characteristics. A high resonant frequency is extremely important in applications where servo control drive systems are used for stabilization or remote control.

## We can supply you with complete specifications for any Wire-Race slewing ring

Rotek's extensive design experience and sophisticated CAD technology are available to assist you in the selection of a Series 15,000 Wire-Race slewing ring that is appropriate for your specific application. This service is available without charge.

To start the design and selection process, contact your local Rotek sales representative or the Rotek application Engineering Department at 800/221-8043.

# Rotek Precision Slewing Rings

Precision slewing rings are required for applications where critical tolerances exist for slewing ring fit, or when specific high performance features and characteristics are required, such as:

- Precision positioning and repeatability
- Low tolerance axial or radial runouts
- Special stiffness or compliance characteristics
- Preload in the raceway system, coupled with a low torque requirement
- Gear precision > AGMA 10

Typical application where precision slewing rings are either essential or desirable include:

- Precision rotary turntables for machine tools
- Index tables
- Robotics for precision positioning
- Medical diagnostic equipment
- Bottle filling equipment for beverage lines
- Radar and radio telescope antennas
- Test stands and testing equipment

The degree of precision in a slewing ring depends primarily on the accuracies attainable in the machining process. The need to machine slewing ring components to close tolerances is most obvious in applications that require a slewing ring with critical feature size or fit specifications.

Machining accuracy is also important to the performance characteristics of equipment that require positioning accuracy and repeatability. Rotek's sophisticated machining capabilities produce slewing rings with the concentricities, parallelism, flatness of surfaces and runouts needed to meet your most demanding precision positioning and repeatability requirements.

Here's a summary of the capabilities and features of our line of large-diameter Precision Slewing Rings:

- Available in raceway diameters of 12" to 180", with larger sizes available
- Available in three configurations
  - Single row, ball
  - Single row, roller with alternating axes (cross-roller)
  - Three row, roller
- Minimum runout tolerances to within .0003" depending on raceway diameter and slewing ring configuration\*
- Feature concentricities to within .0003", depending on slewing ring diameter and configuration\*
- Mounting surface flatness to within .0003", depending on slewing ring diameter and configuration\*
- Parallelism to within .0003", depending on slewing ring diameter and configuration\*
- Bolt hole positions to .010" diameter depending on slewing ring diameter and configuration.\*

\* Raceway diameter and configurations may affect capabilities. Check Rotek for details.

Although every application varies to a degree, in general, your selection of a Rotek Precision Slewing ring should be based on five criteria:

- Accuracies
- Rotational speed
- Load capacity guidelines
- Slewing ring size limitations
- Life requirements

The ability of our Precision Slewing Rings to meet your requirements in these areas depends primarily on the slewing ring's cross section, raceway diameter, and type, size and number of rolling elements. The following is a summary of the different series we manufacture.

## Series 3005P Precision Slewing Rings

Based on their overall capabilities, our Rotek Series 3005P Precision Slewing Rings offer the optimum combination of precision, economy, reliability and durability.

As an evolution of the classic, single row, four-point contact ball slewing rings design, our Series 3005P slewing rings are practical for virtually any heavy-duty application. Utilizing Rotek's unique offset raceway construction and durable ball separators, the Series 3005P provides the highest degree of raceway conformity available.

The offset raceway keeps the load point at a constant distance from the edge of the raceway at both the front and rear of the application. This distinctive design makes the high contact angle practical, resulting in the most efficient utilization of ball capacity.

Balls are separated by individual spacers or cages. Spacers and rolling elements are loaded through loading holes in one of the rings. These loading holes are, in most cases, filled with closely fitted plugs that conform to the raceway contour. Conrad, or slot loaded styles, can also be supplied when requested.

## Series 5005P Precision Cross Roller Slewing Rings

The Series 5005P Cross Roller Precision Slewing Rings can sustain extreme radial, thrust and moment loads whether applied individually or in combination. The two roller paths in each ring, set in V-groove raceways, provide for this universal load carrying capability.

The rollers within the Series 5005P have a length slightly less than their diameter, and are positioned between the rings so the adjacent rollers contact a different raceway. Therefore, the axes of adjacent rollers are always at right angles to each other. By alternating rollers in this manner, half of the rollers transmit the load in one direction and the other half transmit the load in the opposite direction.

The advantage of this cross roller slewing ring construction is greater stiffness – resulting in a lower spring rate. This makes the Series 5005P ideal in situations such as machine tool applications where deflection under load must be minimized.

The Rotek Cross Roller Slewing Ring Series can also have a higher theoretical dynamic capacity per unit size than a single row ball slewing ring. However, mounting structure considerations are critical when utilizing Series 5005P slewing rings because of the possibility of severe torque penalties.

## Series 10,005P Precision Slewing Rings

Equipped with three independent rows of rollers, separated by either steel cages or individual plastic spacers, the Series 10,005P Precision Slewing Rings offer more capacity per unit size than any other Rotek design.

Since all loadings are transmitted directly by raceway surfaces perpendicular to the load direction, the capacity of each rolling element and raceway surface within the Series 10,005P is utilized in the most efficient manner.

With this three roller design, there is no separating force and minimal deflection, which makes the Series 10,005P the stiffest construction style Rotek has ever produced. In addition, the Series 10,005P offers the lowest frictional torque of all our Rotek slewing rings, under most load conditions.

Since the three row roller slewing ring is capable of transmitting very high loadings, it is necessary for it to be mounted on a structure sufficiently uniform in stiffness. This ensures properly distributed loading around the slewing ring. Overall, the Series 10,005P Precision Slewing Rings provide the optimum combination of minimum runout, maximum stiffness, low friction, long life and high reliability.

# Rotek Precision Slewing Ring Selection Chart



This chart contains additional information to help you select the right Rotek Precision Slewing Ring for your specific application.

Note: For information on Rotek Precision Slewing Rings with raceway diameters over 60 inches, contact our Application Engineering Department.

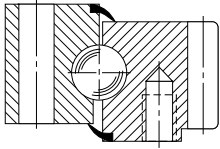
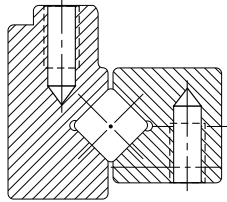
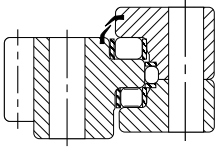
For assistance in determining which Rotek Precision Slewing Ring should be specified for your application, or for a detailed drawing of a specific slewing ring, contact our Application Engineering Department at 800/221-8043.

Series	Typical Cross Section
3005P	
5005P	
10,005P	

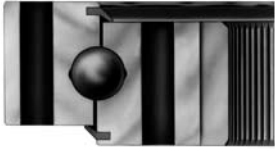
# Rotek Precision Slewing Ring Selection Chart

Typical Design	Construction Configuration	Available Raceway Diameters	Minimum Runout Tolerance At Selected Raceway Diameters	
			Raceway	Tolerance
	Single row ball, four point contact with offset raceways for combined thrust, moment and radial loading.	12" - 180"	12" 20" 30" 40" 50" 60"	.0003" .0003" .0003" .0003" .0004" .0006"
	Single row roller with alternating axes. Cross roller slewing ring provides greatest theoretical dynamic capacity per unit size.	12" - 180"	12" 20" 30" 40" 50" 60"	.0003" .0003" .0003" .0003" .0003" .0003"
	Three row roller, heavy-duty slewing ring with greatest capacity per unit size. Most stringent requirement for mounting structure.	12" - 180"	20" 30" 40" 50" 60"	.0003" .0003" .0003" .0003" .0003"



Notes:



## Rotek Incorporated

Rotek Incorporated  
1400 South Chillicothe Road  
Aurora, Ohio 44202  
Telephone: 330/562-4000  
Toll free: 1-800-221-8043  
Fax: (Sales) 330/562-4620  
Fax: (Engineering) 330/562-2709

Copyright ©2010, Rotek Incorporated  
Printed in U.S.A.



Certificate No. 2132

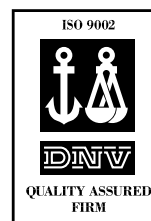

Certificate No. 2205